

**Abstract:**

HSDPA offers theoretical peak downlink data rates up to 14 Mbps and increases the system capacity for downlink packet data. The increased data rates and improved capacity result in shorter delays for the end-users. This is particularly important for some multimedia applications such as interactive games. The high data rates also benefit streaming and web browsing applications. HSDPA is backwards compatible with Release 99 W-CDMA, although it has been added only to Release 5 and later releases. Since most of the modifications that HSDPA introduces occur in the downlink, the base station (BTS) transmitter and the user equipment (UE) receiver are mostly affected. In terms of testing, additional tests are required to verify the HSDPA performance and functionality, mainly in the UE. The Release 5 specifications add very few UE transmitter and receiver characteristic measurements. However, there is a whole new section for UE HSDPA performance requirements testing, which deal mainly with receiver processes and other layer 1 and 2 baseband functionality.

The objective of this paper is to explain the meaning and the purpose of the new HSDPA performance requirements tests that are part of the Release 5 specifications. It also discusses a few additional measurements and alternative test setups that can be used by UE developers to verify the HSDPA functionality and performance of their designs. Knowledge of the basic concepts of HSDPA technology or previous reading of the paper "Concepts of HSDPA", which provides an overview of the basic concepts of HSDPA, is assumed. Previous knowledge of W-CDMA concepts and measurements is also assumed.

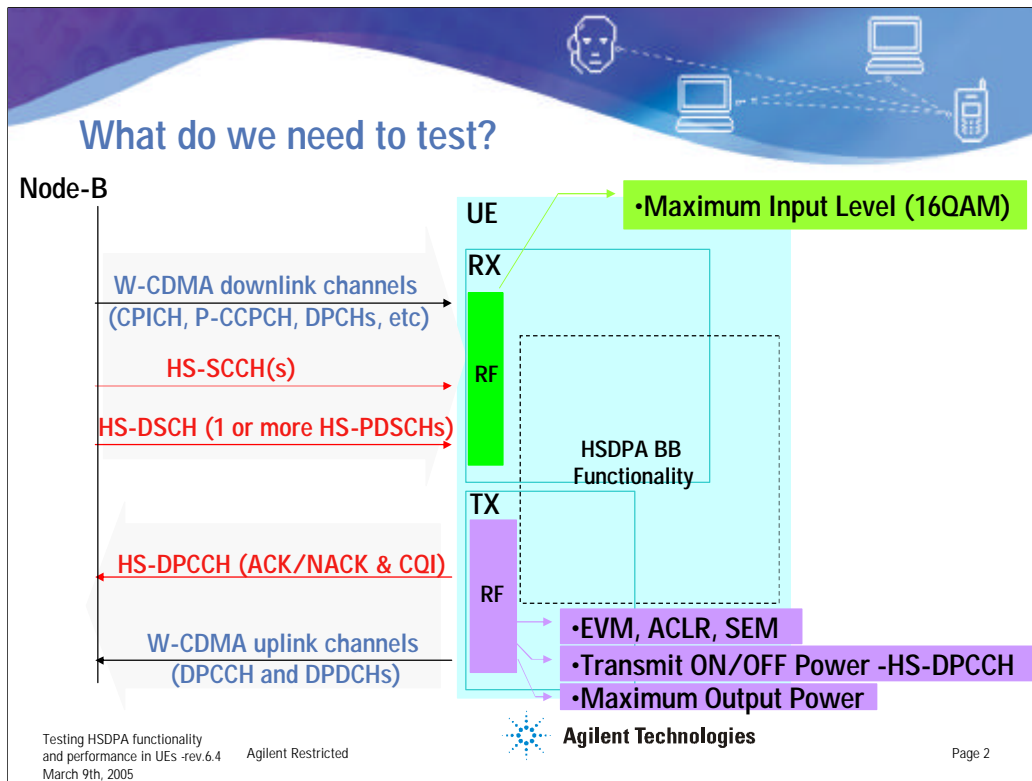

HSDPA is an addition to W-CDMA which mainly affects the downlink. The new downlink and uplink channels are highlighted in red in the slide. This has two implications:

-The HSDPA capabilities mainly affect the BTS transmitter and downlink functions and the UE receiver (including the new HSDPA baseband functionality). There is some need to test the BTS HSDPA receiver capabilities (for example, to verify that the BTS is capable of correctly receiving the ACK/NACK and CQI reports from the UE) and to test the effects of HSDPA on the UE transmitter (for example, the effect of the bursted HS-DPCCH on the uplink signal), but most of the HSDPA testing concentrates on the BTS transmitter and UE receiver. This presentation focuses on the UE, so BTS HSDPA tests will not be covered.

-The UE RF transmitter and RF receiver performance is already tested by the usual W-CDMA tests, and the addition of HSDPA channels should have little or no effect on the RF transmitter or receiver characteristics (such as sensitivity, adjacent channel selectivity, etc) performance of the UE. There are a couple of exceptions to this:

-Since the HSDPA downlink physical data channels may use 16 QAM instead of QPSK, there should be a minimum error rate requirement for these channels. 16 QAM is only used when the link conditions are good (i.e. when the received power at the UE is high), so it does not make sense to test the reference sensitivity level for the 16 QAM channels. However, it is necessary to test the maximum input level for reception of the 16 QAM HS-PDSCH channels, as described in the specifications.

-The HS-DPCCH can add up to about 1.5 dB to the peak-to-average power ratio of the uplink signal. This might have an impact on the design of the UE's PA and RF front-end. Analysis of the power statistics using the Complementary Cumulative Distribution Function (CCDF) might be required. According to the specifications for the UE transmitter, the minimum requirements for Error Vector Magnitude (EVM), Adjacent Channel Leakage Ratio (ACLR), and Spectrum Emissions Mask (SEM), must be tested using signals that include the HS-DPCCH. There are also new UE transmitter requirements to verify that the absolute power ratios and the relative power ratios for the DPCH and the HS-DPCCH are correct, as the ACK/NACK and CQI slots in the HS-DPCCH go on and off. In addition, the UE transmitter maximum output power specification has been relaxed to account for the difference in peak-to-average power ratio.

The tests described above represent a small portion of the overall HSDPA testing required. The new HSDPA features and functions mostly affect the baseband. Most of the testing required to evaluate the UE's HSDPA

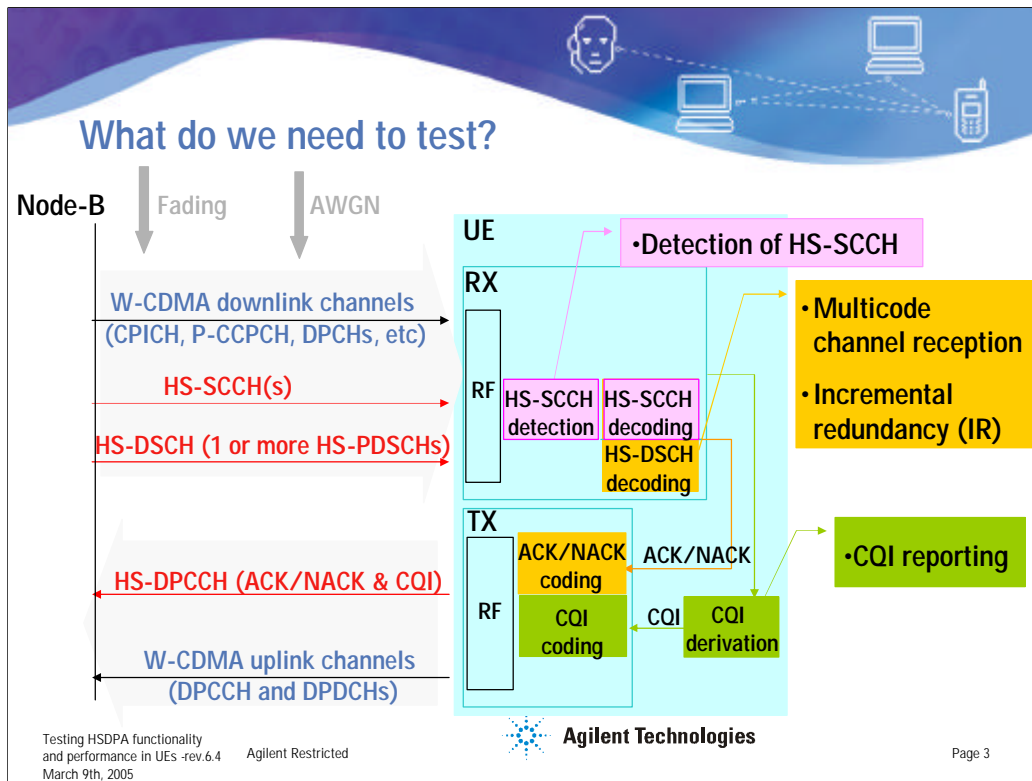

The UE functionality and performance of the new features and techniques that make HSDPA possible (such as HARQ, or AMC) mostly affect the baseband section of the UE. To truly evaluate their performance, the tests need to be run under fading and AWGN conditions. There are three main areas of test that cover the new UE HSDPA features and functions highlighted in the slide. These areas coincide with the performance requirements conformance tests for HSDPA described in Release 5 of the 3GPP specifications (25.101 or 34.121 section 9):

- Decoding of the HS-DSCH: This test verifies the overall performance of the HS-DSCH decoding, including the reception of HS-DSCH channels with multiple HS-PDSCHs and the HARQ functionality, in particular the Incremental Redundancy (IR) combining scheme. The ACK/NACK coding and HS-SCCH decoding are implicitly tested.

- CQI Reporting: This test verifies the performance of the CQI reporting procedure, which is crucial to the AMC functionality and therefore to overall system performance. This test mainly measures the accuracy of the CQI derivation. The CQI coding is implicitly tested.

- HS-SCCH Detection Performance: This test verifies the performance of the HS-SCCH detection and decoding. Without correct detection of the HS-SCCH signaling to the UE, decoding of the HS-DSCH and CQI reporting is not even possible.

This presentation focuses on these performance measurements of the new HSDPA features and functionality.



**What do we need to test?**  
-From the standards point of view-

**UE (Parametric) Conformance Requirements in 25.101:**

**Section 6 - Transmitter characteristics**

- 6.2.2 Maximum Output Power with HS-DPCCH
- 6.5.5 Transmit ON/OFF Power – HS-DPCCH
- 6.6.2.1 SEM; 6.6.2.2 ACLR; 6.8.2 EVM

**Section 7 – Receiver Characteristics**

- 7.4.2 Maximum Input Level for HS-PDSCH Reception (16QAM)

**Section 9 – HSDPA Performance Requirements – *New HSDPA Test Section!!***

- 9.2 Demodulation of HS-DSCH
- 9.3 Reporting of CQI
- 9.4 HS-SCCH Detection Performance

Testing HSDPA functionality and performance in UEs -rev.6.4  
March 9th, 2005

Agilent Restricted

 **Agilent Technologies**

Page 4

The following is a summary of the HSDPA test additions to the UE (parametric) conformance requirements in Release 5:

Five (new or modified) transmitter test requirements (in 25.101 section 6):

- Maximum Output Power with HS-DPCCH (25.101 6.2.2): The purpose of this requirement is to relax the output power requirement for HS-DPCCH transmission to account for the increase in the peak-to-average power ratio.
- Transmit ON/OFF Power – HS-DPCCH (25.101 6.5.5): The purpose of this test is to verify that the DPCH and the HS-DPCCH absolute powers and power ratios are correct during uplink transmission using the bursted HS-DPCCH.
- SEM (25.101 6.6.2.1), ACLR (25.101 6.6.2.2), and EVM (25.101 6.8.2) need to be tested using an uplink signal with the HS-DPCCH.

One new receiver characteristics test requirement (in 25.101 section 7):

- Maximum Input Level for HS-PDSCH Reception (16 QAM) (25.101 7.4.2): The purpose of this requirement is to verify that the UE can sustain a minimum throughput ( i.e. a low block error rate) when receiving a high power signal with 16 QAM HS-PDSCH channels.

A whole new HSDPA Performance Requirements section (25.101 section 9) with three main test sections:

- Demodulation of HS-DSCH (25.101 9.2): The purpose of this test is to verify the overall performance of the HS-DSCH demodulation and decoding.
- Reporting of CQI (25.101 9.3): The purpose of this test is to verify the performance of the CQI reporting procedure in the UE.
- HS-SCCH Detection Performance (25.101 9.4): The purpose of this test is to verify the UE's ability to detect the signalling from the appropriate HS-SCCH.

Because of their importance and complexity, this presentation focuses on the new HSDPA performance requirements tests.

## Agenda

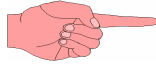

### UE Performance Requirements Test Setups

#### Performance Requirements Tests

- Demodulation of HS-DSCH (34.121 9.2)
- Reporting of CQI (34.121 9.3)
  - AWGN Propagation Conditions (34.121 9.3.1)
  - Fading Propagation Conditions (34.121 9.3.2)
- HS-SCCH Detection Performance (34.121. 9.4)

#### Other Non-Conformance Tests

#### Agilent Solutions

#### Summary

The rest of this paper seeks to provide understanding on what the new HSDPA performance requirements tests mean and how they can be implemented. Even though these tests are part of the conformance specifications, they can be performed with certain modifications during earlier stages of the UE design and development. Some additional non-conformance measurements for early UE design verification are also discussed.

Alternative test setups and solutions for these stages are described as well.

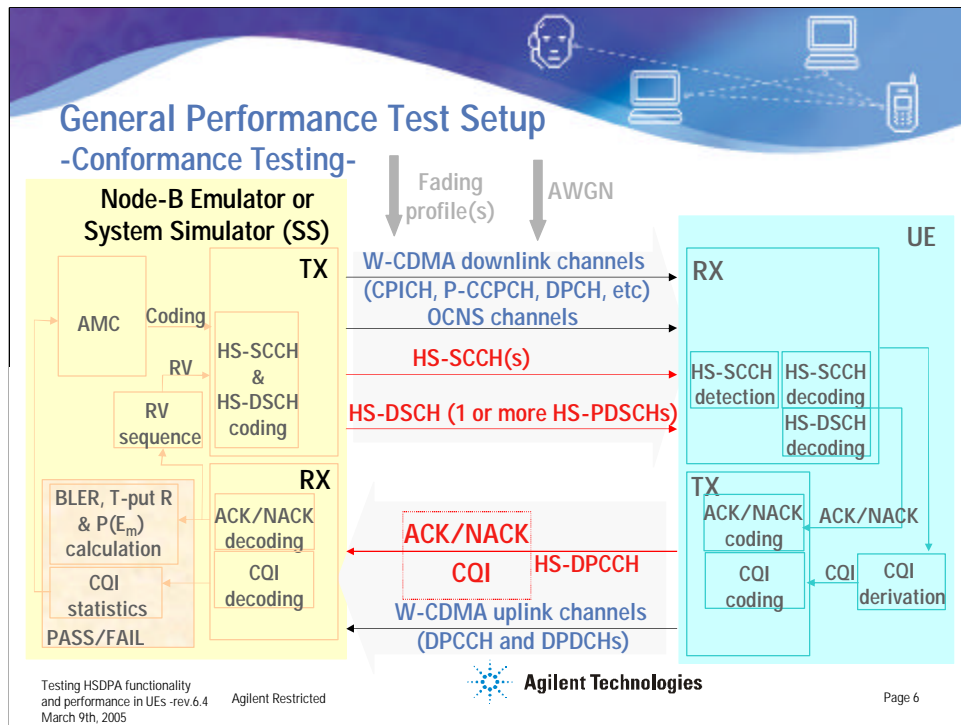

The general conformance test setup for HSDPA performance testing assumes that a connection is established. Therefore, a Node-B Emulator or System Simulator (SS) must be used. The SS must provide the correct coding for the W-CDMA and HSDPA downlink channels and OCNS channels required for each specific test. It must also be capable of correctly decoding the ACK/NACK and COI reports from the UE and responding to them by changing the HS-SCCH and HS-DSCH parameters accordingly, as described in the test procedure section of the specifications. Reception of the W-CDMA uplink channels (DPCCH and DPDCH(s)) is required to provide phase and timing synchronization to decode the HS-DPCCH properly.

The SS must also be able to provide a PASS/FAIL decision based on the minimum requirements specified for each test. Different metrics are used to calculate the UE's performance for the different tests. As opposed to W-CDMA tests, no loopback of received bits is used to provide BER or BLER metrics. Even though BLER is used for some of the tests, it is directly calculated from the ACK/NACK report from the UE. The ACK/NACK report is also used for other tests to calculate the throughput (t-put) R or the probability for certain events, which are used as metrics. The COI reports from the UE are also used to determine the UE's performance and PASS/FAIL decision for some tests.

Fading profiles and AWGN might be provided by the system simulator itself, or if not available, by external faders and AWGN sources.

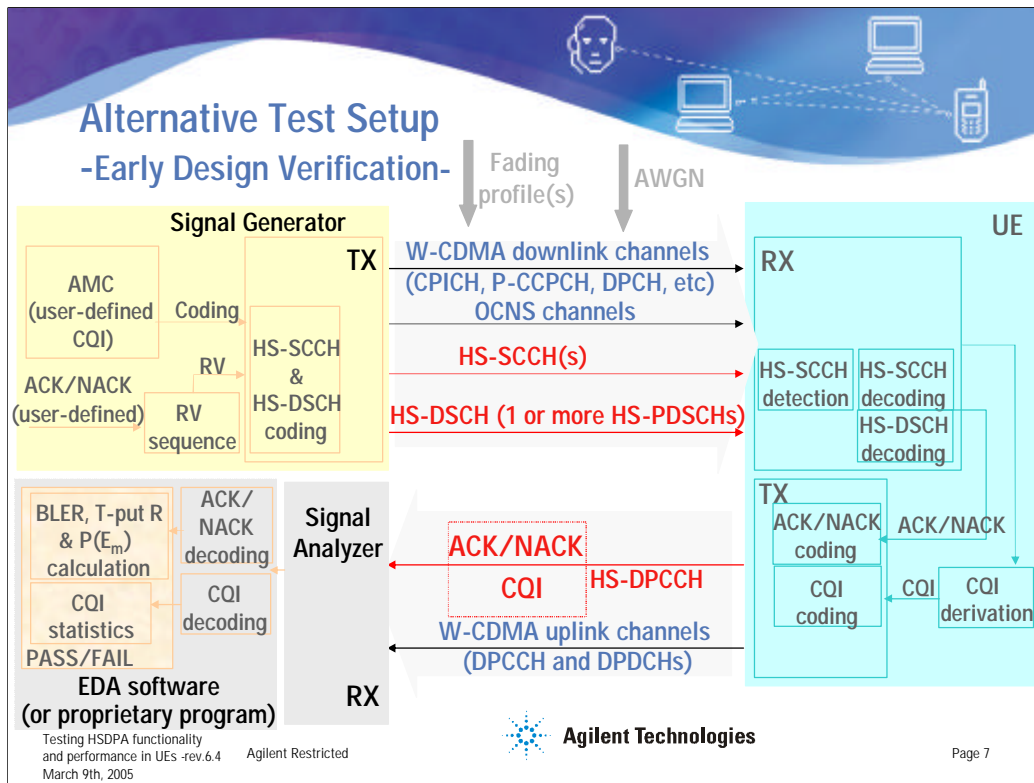

Even though a SS is required for conformance testing, other alternative test setups might be a better option during earlier stages of the design and development process, if we are testing parts of the UE design or full functionality to establish a connection is not available. The actual test setup depends on the DUT, the design stage, and the test itself. Other considerations might be the availability of some of the tools if they are also used to test the design's W-CDMA performance, for example.

There are three main parts of the test process: stimulus generation, ACK/NACK and CQI reception/decoding, and calculation of the performance metrics.

In terms of stimulus generation, a typical setup during these earlier stages includes a signal generator capable of generating correct fully coded HSDPA channels (in addition to the W-CDMA and OCNS downlink channels) and that supports user-defined ACK/NACK and CQI patterns that allow downlink parameter changes according to a simulated response from the UE. Fading profiles and AWGN might be provided by the signal generator itself, or if not available, by external faders and AWGN sources.

The HS-DPCCH reception can be performed using a signal analyzer. As in the case of conformance testing, reception of the W-CDMA uplink channels (DPCCH and DPDCH(s)) is required to provide phase and timing synchronization to demodulate the HS-DPCCH properly. Even though the signal analyzer can demodulate the signal into encoded bits, it cannot decode the ACK/NACK and CQI fields into their real values. This step can be performed manually or, if working with EDA tools that provide connectivity with test equipment, such as ADS, it can be performed by a behavioral HSDPA uplink decoder within this environment.

The final calculation of the performance metric must also be user implemented, either as part of a routine within the same EDA environment, or as an external program.

The main drawback of these alternative solutions is the lack of a feedback loop between the UE and the signal generator, which would be difficult to implement. Although the user input capabilities in the signal generator attempt to provide a substitute to this, it is not a very functional solution for some of the tests and can definitely not be used for conformance testing.

The other drawback of these alternative setups is obviously the inconvenience of dealing with different tools and of having to implement some of the measurement routines and calculation algorithms. This can be somewhat minimized by using signal generation, analysis and EDA tools that follow consistent and compatible algorithms for the HSDPA coding and decoding processes, and that can be inter-connected. The objective of this paper is to provide understanding to facilitate the development of measurement routines and calculation algorithms.

On the other hand, these alternative setups are more flexible, and might allow more variation in the measurement routines than SS solutions, which are mainly designed for conformance testing and manufacturing. Also, some of these tools can be used for thorough testing of the design and for troubleshooting. For example, signal generators can typically create both downlink and uplink signals, with different fully encoded signal configurations, which can be used as a design reference. Signal analyzers can be used to explore problems in the ACK/NACK or CQI demodulated bits.

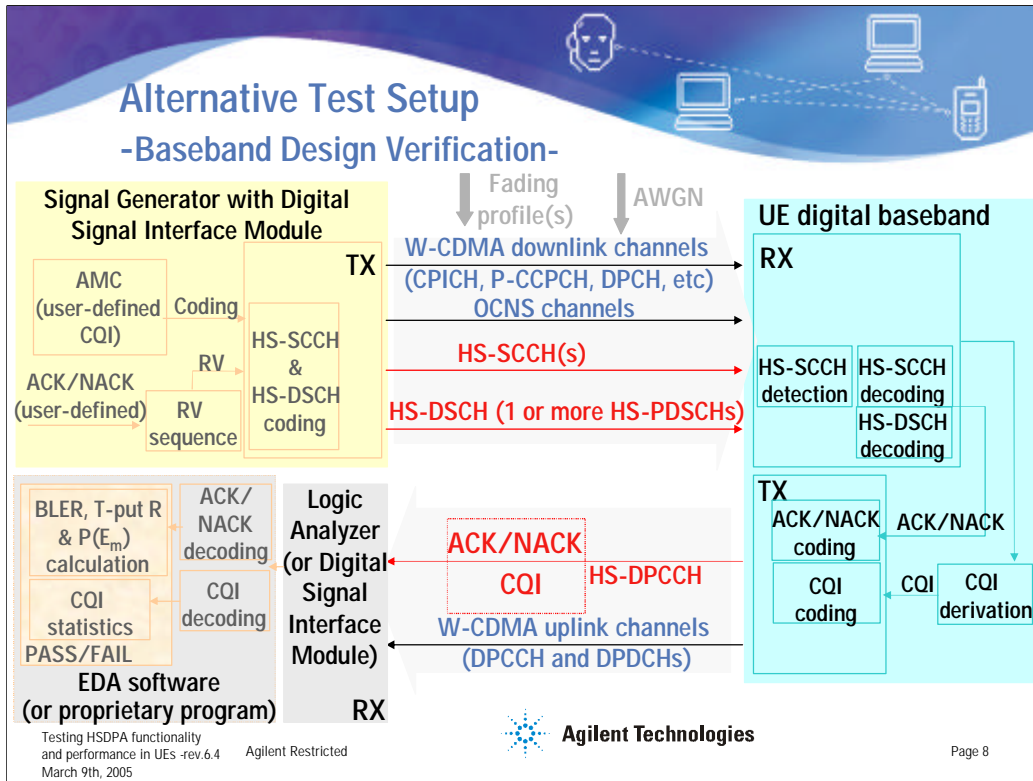

A similar setup can be used if the DUT has digital inputs/outputs. The main differences is that the signal generator must have digital outputs and that a logic analyzer (or some kind of digital signal interface) should be used instead of the signal analyzer to capture the uplink signal prior to decoding. If using EDA software, it is advisable to use a logic analyzer or digital signal interface module that has connectivity to the EDA software tool.



## Agenda



### UE Performance Requirements Test Setups

### Performance Requirements Tests



- Demodulation of HS-DSCH (34.121 9.2)
- Reporting of CQI (34.121 9.3)
  - AWGN Propagation Conditions (34.121 9.3.1)
  - Fading Propagation Conditions (34.121 9.3.2)
- HS-SCCH Detection Performance (34.121. 9.4)

### Other Non-Conformance Tests

### Agilent Solutions

### Summary

The performance requirements tests as described in the specifications will be discussed next. First, the Demodulation of HS-DSCH test (34.121 9.2) will be explained.

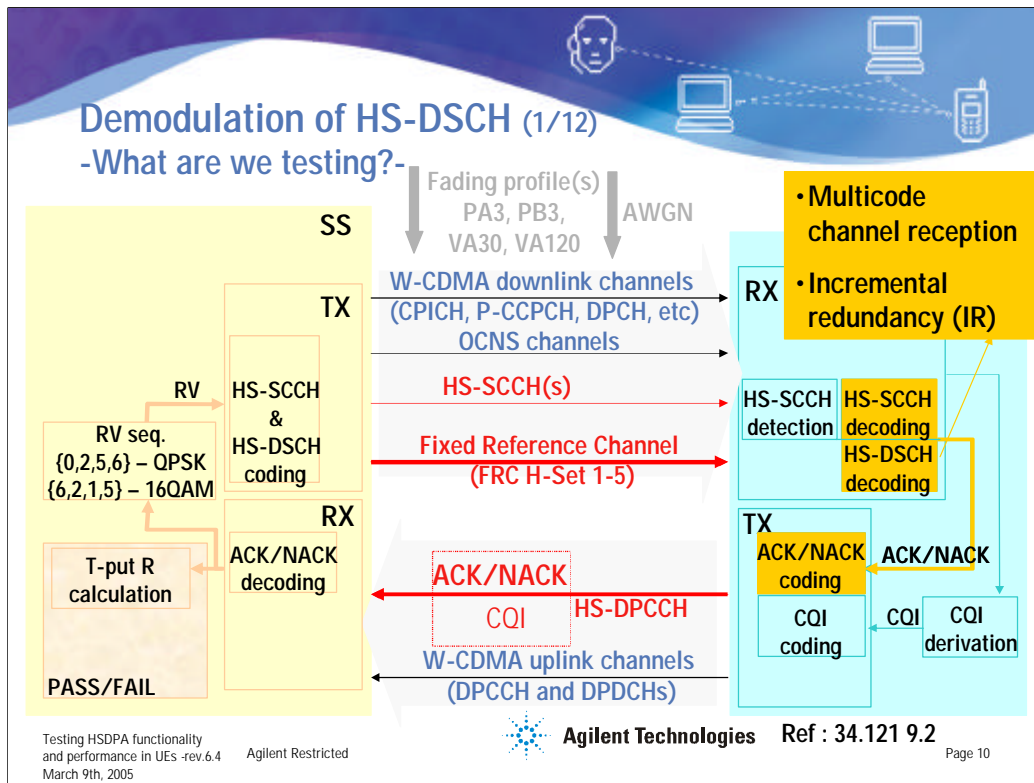

The Demodulation of HS-DSCH test is equivalent to the demodulation performance requirement tests for W-CDMA dedicated channels. It tests the HS-DSCH decoding performance of the UE, in particular the most challenging aspects: multicode channel reception and the IR HARQ combining scheme.

The HS-DSCH is configured as a Fixed Reference Channel (FRC). There are five different FRC sets (FRC H-Set 1 to 5), that correspond to different UE categories. FRCs are analogous to the reference measurement channels (RMCs) in W-CDMA. The term 'fixed' in this case refers to the fact that the modulation and coding for these test configurations remains fixed, so AMC is not applied. This means that the CQI report is not important for this test, so it is disregarded. This makes sense since we are interested in the performance of the multi-code reception and the HARQ functionality which are independent of the AMC process. The different UE categories and an example of the coding for an FRC set will be shown in the following slides.

The minimum requirements are specified in terms of information bit throughput (t-put) R, depending on the UE category. This is calculated from the ACK/NACK report.

In addition to the fixed reference channel, the SS must transmit the associated HS-SCCH, and the W-CDMA downlink channels required to establish and maintain a connection. The channel configuration for the DPCH corresponds to the RMC 12.2 kbps. Refer to 34.121 section E.5.1 for more information on the configuration for the downlink physical channels. 6 OCNS channels are also transmitted to account for the energy transmitted to other users in a real BTS (see 34.121 section E.5.2).

The test must be performed under different multi-path fading and AWGN propagation conditions. Several fading scenarios must be considered: ITU Pedestrian A Speed 3km/h (PA3), ITU Pedestrian B Speed 3km/h (PB3), ITU vehicular Speed 30km/h (VA30), and ITU vehicular A Speed 120km/h (VA120). These scenarios correspond to profiles with 4 to 6 paths and Doppler spectrum. Refer to 34.121 section D.2.2 table D.2.2.1A for more details on these fading profiles.

**Demodulation of HS-DSCH (2/12)**  
**-UE Capability Classes-**

HS-DSCH category (FDD)	Maximum number of HS-DSCH codes received	Minimum inter-TTI interval	Maximum number of bits of an HS-DSCH transport block received within an HS-DSCH TTI	Total number of soft channel bits
Category 1	5	3	7298	19200
Category 2	5	3	7298	28800
Category 3	5	2	7298	28800
Category 4	5	2	7298	38400
Category 5	5	1	7298	57600
Category 6	5	1	7298	67200
Category 7	10	1	14411	115200
Category 8	10	1	14411	134400
Category 9	15	1	20251	172800
Category 10	15	1	27952	172800
Category 11	5	2	3630	14400
Category 12	5	1	3630	28800

UEs of Categories 11 and 12 support QPSK only. Ref : 25.306 4.5.3 and table 5.1a

Testing HSDPA functionality and performance in UEs -rev.6.4  
 March 9th, 2005

Agilent Restricted



**Agilent Technologies**

Page 11

The channel configuration, test parameters, and minimum requirements for the demodulation of HS-DSCH test depend on the UE category. The table from the specifications defining the UE categories (HS-DSCH physical layer categories (FDD) from 25.306 (table 5.1a)) is shown above. The main parameters used to define the UE physical layer capabilities are the following:

- The maximum number of HS-PDSCHs supported for an HS-DSCH.
- The minimum inter-TTI interval, which defines the maximum number of parallel HARQ processes that the UE can support. For example, for category 5, the minimum inter-TTI interval is 1, so the UE must be capable of receiving up to 6 parallel HARQ processes.
- The maximum number of HS-DSCH transport bits that can be received within a single TTI. This is equivalent to the maximum transport block size per TTI allowed.
- The maximum number of soft channel bits over all the HARQ processes. The number of soft channel bits per HARQ process corresponds to the size of the virtual IR buffer per process. The role of the virtual IR buffer will be explained in more detail in the following slides. The total number of soft channel bits over all HARQ processes defines the memory size that must be allocated in the UE for correct decoding of the HS-DSCH.
- Support for 16 QAM, or QPSK only.

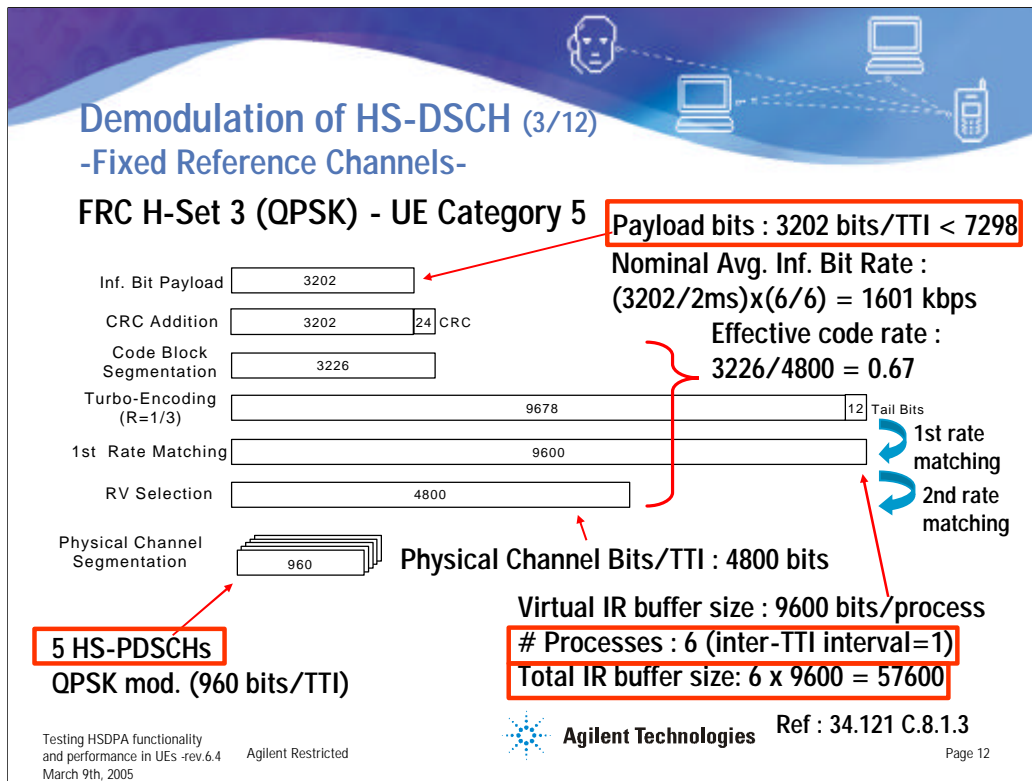

As mentioned earlier, the FRC H-sets are the fixed HS-DSCH channel configurations used during the demodulation of HS-DSCH test for the different UE categories. Therefore, the coding parameters for a certain FRC H-Set have to match the parameters that define the corresponding UE category.

For example, the coding for the FRC H-Set 3 configuration is shown in the slide. The FRC H-Set 3 is the FRC set assigned to UE Categories 5 and 6. The coding in the slide corresponds to the QPSK configuration of FRC H-Set 3. There is also a 16 QAM configuration for this FRC set, that will be reviewed in the next slide.

The relationship between the coding parameters for the FRC H-Set 3 (QPSK configuration) and the parameters that define UE category 5 is highlighted in red. For an FRC, the number of information bits is equivalent to the transport block size (so, all the bits in the transport block are considered information bits). The number of information bits (3202) is smaller than the maximum number of bits in a HS-DSCH transport block for category 5 (7298).

The virtual IR buffer size per process is 9600 bits, and there are 6 processes. Therefore the total IR buffer size is 57600 bits. These parameters match the parameters for category 5.

The number of HS-PDSCH channels is 5, which is equal to the maximum number of HS-PDSCHs for UE category 5. The number of HS-PDSCHs and the modulation format define the number of physical channel bits after RV selection (960 bits x 5 = 4800 bits).

Other parameters of interest that will be used during the rest of the presentation are the nominal average information bit rate and the effective code rate.

The number of payload bits and the number of processes define the nominal average information bit rate ((number of payload bits/2 ms) x (number of processes/6)). The 2 ms correspond to the TTI duration. For example, if only 1 data block were sent every 6 TTIs (maximum number of processes = 1), the nominal average information bit rate would be 1601/6. In this case, the number of parallel processes is 6, which means that a block of data is sent every TTI, so there are no blank or discontinued transmission (DTX) TTIs. Therefore, the nominal average information bit rate for the FRC H-Set 3 (QPSK configuration) is much higher (1601 kbps). Remember that the actual bit rate for any FRC will ultimately be determined, not only by the nominal average information bit rate, but also by the decoding and HARQ performance (number of information bits successfully received over time), which is basically what the Demodulation of HS-DSCH test is trying to calculate.

Even though the turbo-encoding code rate is fixed at 1/3, the effective code rate corresponds to the combination of turbo-encoding and rate matching. So, the effective code rate for any HS-DSCH configuration can be calculated if the transport block size (which, as we mentioned earlier, in this case is equivalent to the number of information bits), the number of HS-PDSCHs and the modulation format are known. In this case the effective code rate is  $0.67 = (3202+24) \text{ bits} / (960 \text{ bits} \times 5)$

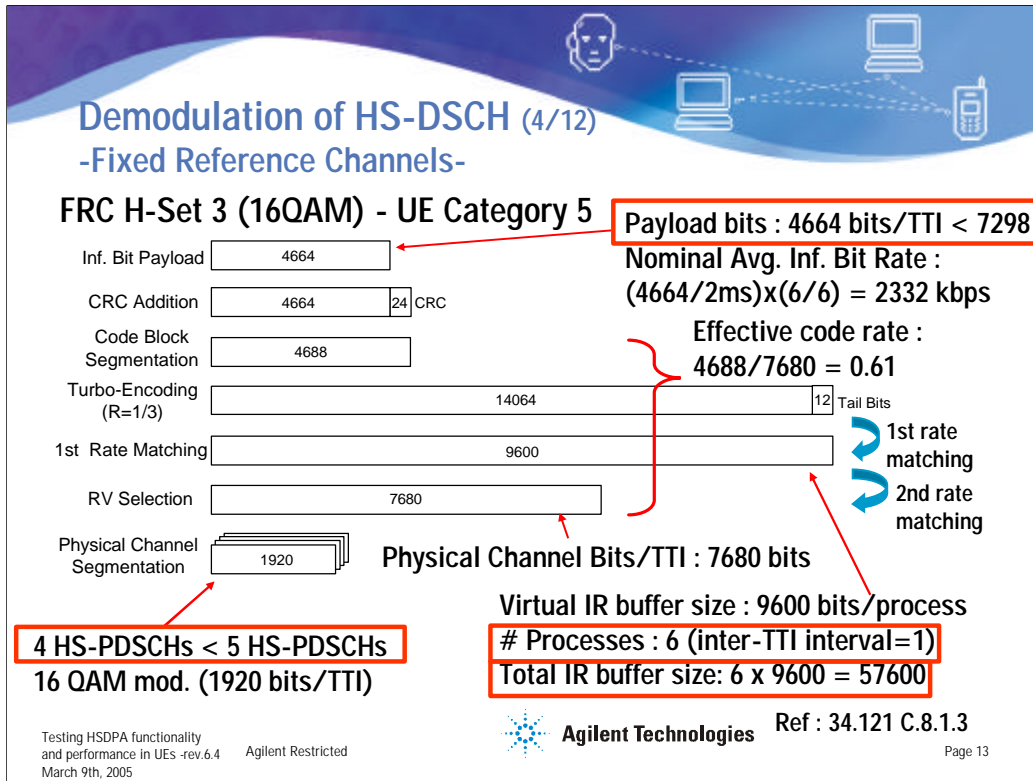

This is the configuration for the FRC H-Set 3 (16QAM). In this case there are 4664 information bits/TTI and there are 6 processes, so data is transmitted in all TTIs again, and the nominal average information bit rate is 2332 kbps. The modulation scheme is 16 QAM, and there are 4 HS-PDSCHs, so the effective code rate is  $(4664+24) \text{ bits} / (1920 \text{ bits} \times 4) = 0.61$ .

Even though the effective code rate is a little bit lower relative to the QPSK configuration, the nominal average information bit rate is higher because of the 16 QAM modulation.

Note that the effective code rate calculated in these examples does not take into consideration potential retransmissions.

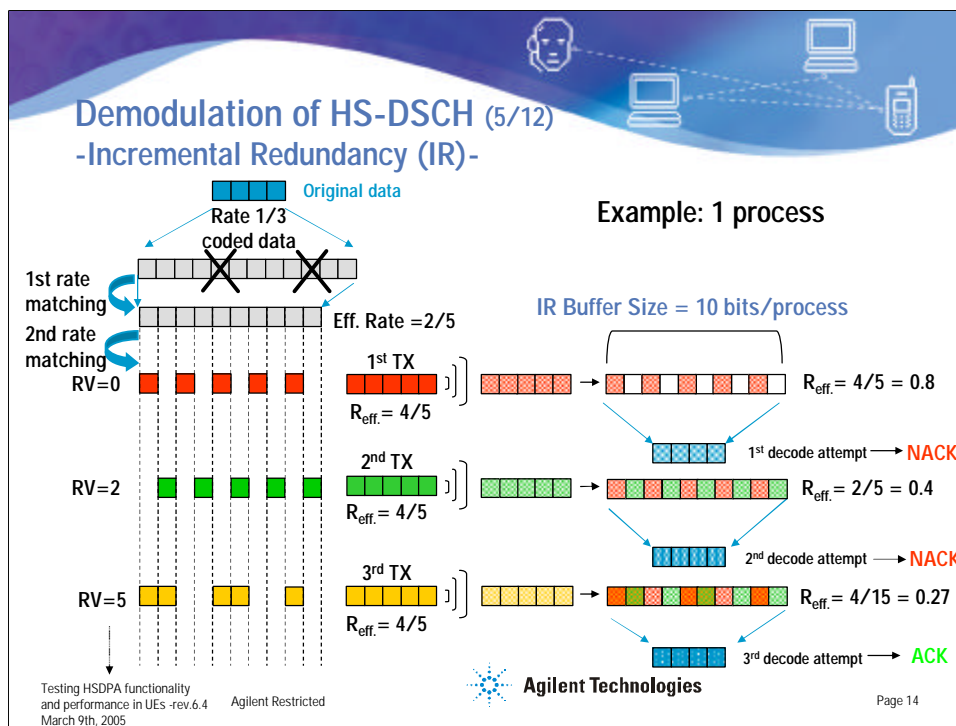

In order to understand the meaning and significance of the demodulation of HS-DSCH test it is useful to review some of the key elements of the HS-DSCH coding, in particular, the HARQ functionality and the IR combining scheme. This slide uses an example to demonstrate how the IR combining scheme works. For simplicity, an IR buffer size of 10 bits/process and a single process will be assumed.

The original data (4-bits in blue in the example) corresponds to the data block after the CRC is added. This data is turbo-encoded at rate 1/3 (for every bit that goes into the coder, there are three bits out).

This data then gets punctured as part of the first rate matching stage. The objective of this stage is to match the number of output bits to the IR buffer size (10 in this case).

The second rate matching stage (RV selection) punctures the data again. The data can be punctured into different data sets, each corresponding to a different redundancy version. The different redundancy versions are demonstrated by the three colors red, green, and orange. Only one of these data sets is sent in any one transmission.

The 5 red bits (RV=0) are sent on-the-air (OTA), resulting in an effective code rate of 4/5, i.e. for every original data bit, (1+1/4) bits are transmitted OTA. This data arrives at the UE and is demodulated and then padded out with dummy bits into the IR buffer (the dummy bits are not relevant since they are not known and there is a 50% chance of getting them correct). This is then decoded to provide the 4 blue bits with some possibility of error. This block of data is then checked against the CRC. If the block is in error, it is stored and a NACK is sent to request a retransmission.

The retransmission is sent with a different RV or puncture scheme (RV=2, green). The 5 green bits are sent OTA. At the UE they are recombined with the red bits from the first transmission, resulting in an effective code rate of 2/5, i.e. for every data bit there are now 2 1/2 bits for the decoding, which provides a greater chance of correctly decoding the data. This is then checked against the CRC. If the block is still in error, it is stored and a NACK is sent to request a retransmission again.

This time the retransmission is sent again using a different RV or puncture scheme (RV=5, orange). Notice that the different RVs do not necessarily consist of completely different bits. Some of the bits may be repeated in different RVs. The 5 orange bits are sent OTA, recombined at the UE with the red and green bits from the first and second transmissions. Notice that the IR buffer might be already full, but the new RV still provides additional redundant data, even if some of the encoded bits (or all of them) might be repetitions from encoded bits received earlier. In this case, the effective code rate is 4/15, i.e. for every data bit there are now 3+3/4 bits, which provides an even greater chance of correctly decoding the data. In this example, the data is correctly decoded and an ACK is sent back. If the block were still in error, a NACK would be sent and additional RVs could be transmitted, depending on the maximum number of transmissions allowed for a block.

In the case of 16QAM formats, the different RVs not only correspond to different puncturing schemes, but might also correspond to different constellation versions or rearrangements. Since two of the four bits in a symbol have a higher probability of error than the two other bits, the re-arrangements provide equal probability of error to all the bits in average, after retransmission combining.

Please refer to 25.212 sections 4.5 and 4.6 for more information on HARQ coding and the RV redundancy and constellation

## Demodulation of HS-DSCH (6/12) -HARQ ACK/NACK Coding-

HARQ-ACK bits:  $W_0, \dots, W_9 \rightarrow PhCH$

ACK = **1111111111** (all 1)

NACK = **0000000000** (all 0)

HS-DPCCH  
 Slot #0

HARQ-ACK

↓

Channel coding

↓

$W_0, W_1, W_2, \dots, W_9$

↓

Physical channel mapping

↓

Ref : 25.212 4.7.1.1

Testing HSDPA functionality and performance in UEs -rev.6.4  
March 9th, 2005

Agilent Restricted



**Agilent Technologies**

Page 15

The UE indicates successful reception and decoding of a block by sending an ACK. If payload is received, but damaged and cannot be decoded, the UE reports a NACK. If the UE is not expecting data or decides that the data is not intended for it, it does not send either an ACK or a NACK.

The HARQ (ACK/NACK) information is sent via the HS-DPCCH. An ACK is coded as ten '1's and a NACK is coded as ten '0's. The ten encoded bits are mapped into the first slot of the HS-DPCCH. When no ACK or NACK is sent, this slot is DTX.

## Demodulation of HS-DSCH (7/12)

### -HARQ Transmissions-

HS-DPCCH ACK/NACK Field State	Node-B Emulator Behavior
ACK	ACK: new transmission using 1 <sup>st</sup> redundancy version (RV)
NACK	NACK: retransmission using the next RV (up to the maximum permitted number of RV's)
DTX	DTX: retransmission using the RV previously transmitted to the same HARQ process

**RV SEQUENCE:** Maximum number of HARQ transmissions: 4

**{0,2,5,6} – QPSK** ← Redundancy version sequence

**{6,2,1,5} – 16QAM** ← Redundancy and constellation version sequence

Testing HSDPA functionality  
and performance in UEs -rev.6.4  
March 9th, 2005

Agilent Restricted



Agilent Technologies

Ref : 34.121 9.2

Page 16

The slide shows the response of the SS to an ACK/NACK, as described in the Demodulation of HS-DSCH conformance test specifications. The objective is to simulate the behavior of the Node-B. Upon receiving an ACK, the SS must send a new block of data. Upon receiving a NACK, it must send a retransmission using the next RV (up to the maximum number of RVs allowed). Upon receiving a DTX, the SS will retransmit the same block of data using the same RV previously transmitted for the same HARQ process.

The RV sequence to follow is also specified, and it depends on the FRC modulation format. For QPSK configurations, RV=0 is always sent in the first transmission of a block. RVs 2, 5, and 6 are sent in subsequent retransmissions. For 16 QAM configurations, RV=6 is used for the first transmission and RVs 2, 1, and 5 in subsequent retransmissions. The maximum number of HARQ transmissions allowed for this test is 4.



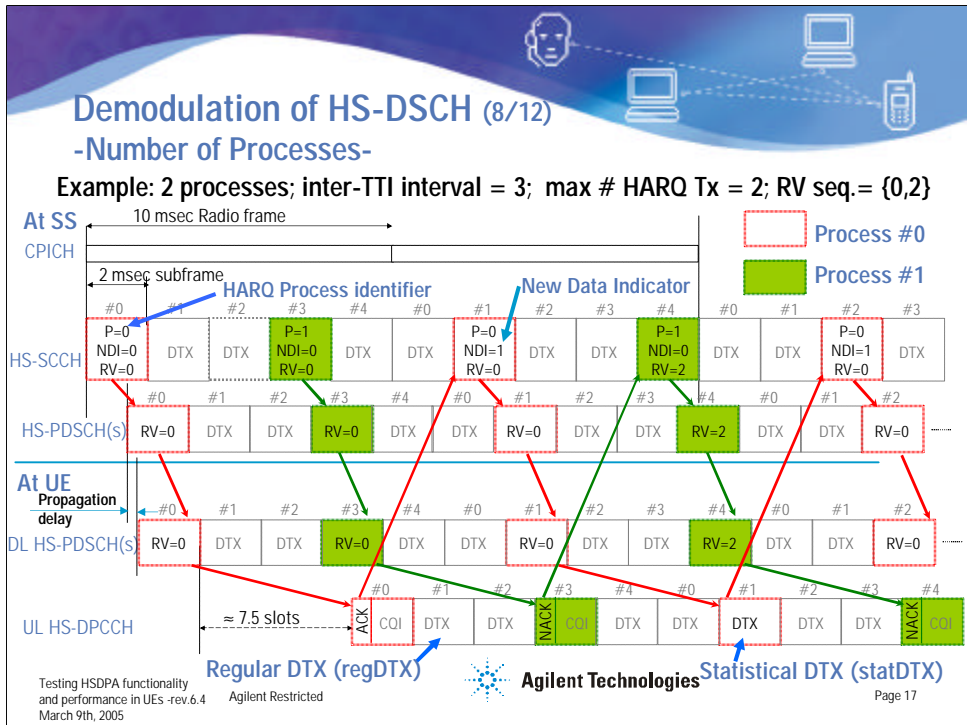

A simplified example of the HARQ functionality is shown above for 2 processes and inter-TTI interval=3. Remember that there are 5 subframes between transmissions/retransmissions for a single process (or 6 TTIs from the beginning of a TTI to the beginning of the following TTI that can be assigned to the same process). The reason for this is that the Node-B receives the ACK/NACK report during the fifth TTI counted from the end (or the sixth TTI from the beginning) of the TTI in which the data block is transmitted. Multiple parallel processes are required to take advantage of the unused TTIs. The maximum number of processes depends on the minimum inter-TTI interval the UE supports. In this case there are 2 processes and there are two DTX TTI's between transmissions of the two processes (inter-TTI interval=3), so this example could apply to all UEs that support minimum inter-TTI intervals of 1, 2, or 3 (so all UE categories).

Note that the FRC assigned to a certain UE category for the Demodulation of HS-DSCH conformance test is configured with as many processes as the corresponding UE category can support, in order to stress this capability in the UE. For example, FRC H-Set 3 has 6 processes, which is the maximum number of processes that UEs of categories 5 and 6 must be able to support.

The HS-SCCH indicates new data being transmitted by toggling the new data indicator (NDI) value between 0 and 1 within the same process (see 25.321 11.6.1.3). So, for a retransmission, the NDI value stays the same and the RV changes to the next in sequence. In this example, a maximum of two HARQ transmissions per block is allowed, and the RV sequence is {0, 2}.

The HS-DPCCH HARQ ACK/NACK field corresponding to a DTX TTI from the SS will also be DTX. These DTX are called regular DTX (regDTX). In real life this is the time when other UEs are served.

If the UE does not correctly identify signaling from the HS-SCCH or consistent control information is not detected on the HS-SCCH, neither ACK, nor NACK, shall be transmitted in the corresponding HS-DPCCH subframe. This DTX response occurs statistically and it is called statistical DTX (statDTX).

**Demodulation of HS-DSCH (9/12)**  
**-TROUHPUT (T-PUT) R versus BLER-**

$$BLER = \frac{(NACK + statDTX)}{(NACK + statDTX + ACK)} \quad (1)$$

$$R = \frac{ACK \times N_{INFO}}{(ACK + NACK + statDTX + regDTX) \times 0.002s} \quad (2)$$

$= \frac{ACK}{ACK + NACK + statDTX + regDTX} \times Nom. \_ Inf. \_ bit \_ rate$   
 $= \frac{ACK}{(ACK + NACK + statDTX)} \times Nom. \_ Avg. \_ Inf. \_ bit \_ rate \quad (3)$   
 $= (1 - BLER) \times Nom. \_ Avg. \_ Inf. \_ bit \_ rate \quad (4)$

Ref : 34.121 F.6.3.2

Testing HSDPA functionality and performance in UEs -rev.6.4 March 9th, 2005      Agilent Restricted       **Agilent Technologies**      Page 18

Block Error Ratio (BLER) is the metric used for most W-CDMA performance requirement tests. BLER is defined as the ratio of unsuccessfully received and decoded blocks to the total number of information blocks sent. In the case of HSDPA, BLER is equal to (NACK + statDTX) / (NACK + statDTX + ACK) as shown in equation (1).

The metric defined for the Demodulation of HS-DSCH conformance test is not BLER. Instead, the minimum requirements for the Demodulation of HS-DSCH test are specified in terms of the information bit t-put R. The measured information bit t-put R is defined as the sum (in kilobits) of the information bit payloads (excluding the 24-bit HS-DSCH CRC) successfully received during the test interval, divided by the duration of the test interval (in seconds) (see 34.121 section F.6.3.1). T-put R is a better indicator of the UE's HS-DSCH demodulation performance since it basically provides the effective data rate for a fixed channel.

Both BLER and t-put R are calculated directly from the HS-DPCCH ACK/NACK reports from the UE. Therefore, only the ACK and NACK signals, not the data bits received by the UE, are accessible to the SS. As opposed to bit error ratio (BER) tests, no loopback of the received bits is required to calculate BLER and t-put R, in this case.

For t-put R, the time in the measurement interval is composed of successful TTIs (ACK), unsuccessful TTIs (NACK) and DTX-TTIs (both regDTX and statDTX), as shown in equation (2). RegDTX occur regularly according to the FRC H-set. So, the number of RegDTX is known to the SS. For a FRC, the number of bits in a TTI is fixed, so the number of information bits per TTI is also known to the SS from knowledge of what FRC was sent. The nominal information bit rate during a regular (non-RegDTX) TTI transmission would be the number of information bits per TTI divided by the TTI duration (2 ms). The nominal average information bit rate for a FRC takes into account the RegDTX. Therefore, t-put R can be defined in terms of the number of ACK, number of NACK, number of statDTX, and the nominal average information bit rate for the FRC used, as shown in equation (3). As a result, BLER can be mapped unambiguously to t-put R for any single FRC, as shown in equation (4). In addition, the t-put R minimum requirements can be translated to BLER minimum requirements for any single FRC.

For example, for FRC H-Set 3 (QPSK), if equation (4) is applied, the bit t-put R = (1/BLER) x 1601 kbps. The same result would be obtained if equation (2) is applied. FRC H-Set 3 has 6 processes, so there are no regDTX. Therefore the result of equation (2) would be R = (ACK / (ACK + NACK + statDTX)) x 1601 kbps, which is equivalent to R = (1 - BLER) x 1601 kbps.

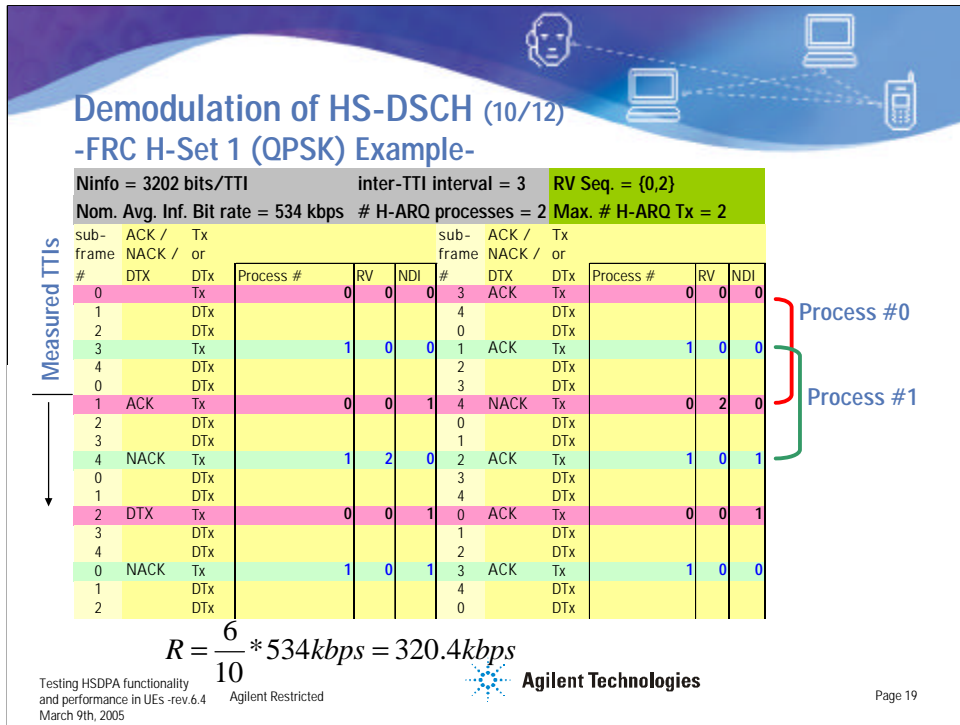

A theoretical example of the measurement results for the FRC H-Set 1 (QPSK) is shown above. As in the shorter example earlier, the maximum number of HARQ transmissions is 2 and the RV sequence is {0,2}.

The ACK/NACK/DTX column here represents the feedback from the UE, and the rest of the columns represent the corresponding response from the BTS to this feedback.

Again, the HS-SCCH indicates new data being transmitted by toggling the NDI value between 0 and 1 within the same process. So, for a retransmission, the NDI value stays the same and the RV changes to the next in sequence (up to the maximum number of retransmissions allowed). Upon reception of a statDTX, the SS sends the same transmitted block with the same RV, so both the NDI value and the RV parameter will stay the same.

The number of successfully received and decoded blocks in this example is 6 (6 ACKs) and the number of ACK, NACK, or statDTX TTIs during the measurement interval is 10. Since the nominal average information bit rate for FRC H-Set 1 (QPSK) is 534 kbps, the information t-put R is 320.4 kbps. The BLER in this case would be 4/10 or 40%.

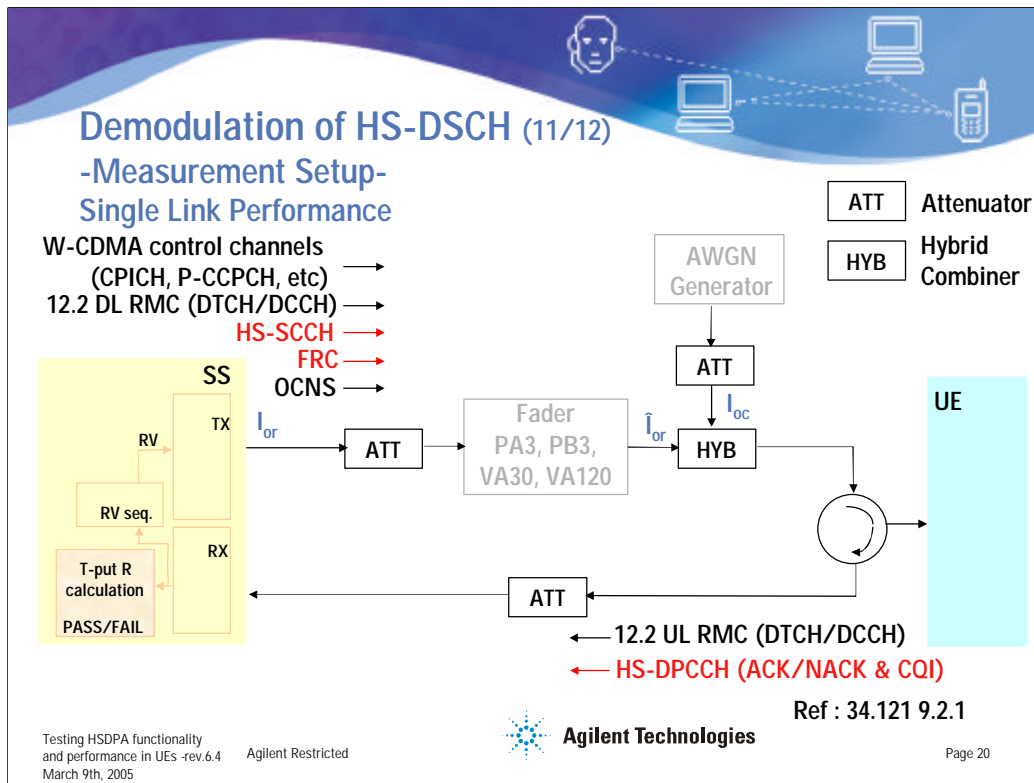

The generic connection diagram for the Demodulation of HS-DSCH, single link performance conformance test is shown above. Fading profiles and AWGN might be provided by the system simulator itself, or if not available, by external faders and AWGN sources.

An HSDPA call must be first set up, and the test conditions and test parameters must be set as described in 34.121 section 9.2.1. The actual test parameters and minimum requirements depend on the UE category. The test is repeated for four different fading scenarios. Each combination of FRC and fading profile can have up to four throughput requirements depending on different signal and noise level parameters.

Even though the minimum requirements using a certain fading profile and test parameter set are different for the different FRC H-Sets, when the t-put requirements are translated to BLER using the formula shown earlier ( $t\text{-put } R = (1 - \text{BLER}) \times \text{nominal average information bit rate}$ ), the BLER requirements coincide for FRC H-Sets 1, 2, and 3. For example, the minimum requirement for FRC H-Set 1 (QPSK), using the PA3 fading profile and  $\hat{I}_{or} / I_{oc} = 10$  dB is  $t\text{-put } R = 309$  kbps. This corresponds to  $\text{BLER} = 1 - (309/534) = 0.42$ . The minimum requirement for FRC H-Set 2 (QPSK), with the same propagation conditions and test parameters is  $t\text{-put } R = 309 \times 1.5 = 464$  kbps, which corresponds to  $\text{BLER} = 1 - (464/801) = 0.42$ . The minimum requirement for FRC H-Set 3 (QPSK), with the same propagation conditions and test parameters is  $t\text{-put } R = 309 \times 3 = 927$  kbps, which corresponds to  $\text{BLER} = 1 - (927/1601) = 0.42$ . The reason for this coincidence in the BLER requirements is that both the t-put minimum requirements and the nominal average information bit rate for a certain FRC H-Set are a function of the number of processes for that particular FRC H-Set (2 processes for FRC H-Set 1, 3 processes for FRC H-Set 2, and 6 processes for FRC H-Set 3). The more the processes, the higher the nominal average information bit rate and the t-put expected for that FRC H-Set.

The information bit data for the FRC must be pseudo random and not repeated before 10 different information bit payload blocks are processed. For example for FRC H-Set 3 (QPSK) the pseudo-random sequence must be at least  $10 \times 3202$  bits long.

The test length is determined by either the fading cycle or by the amount of samples required to get a statistically meaningful result, whichever results in the longest time. The actual test length for the different test scenarios are defined in 34.121 Annex F.6.3 tables F.6.3.5 and vary between 4.1s and 164s.

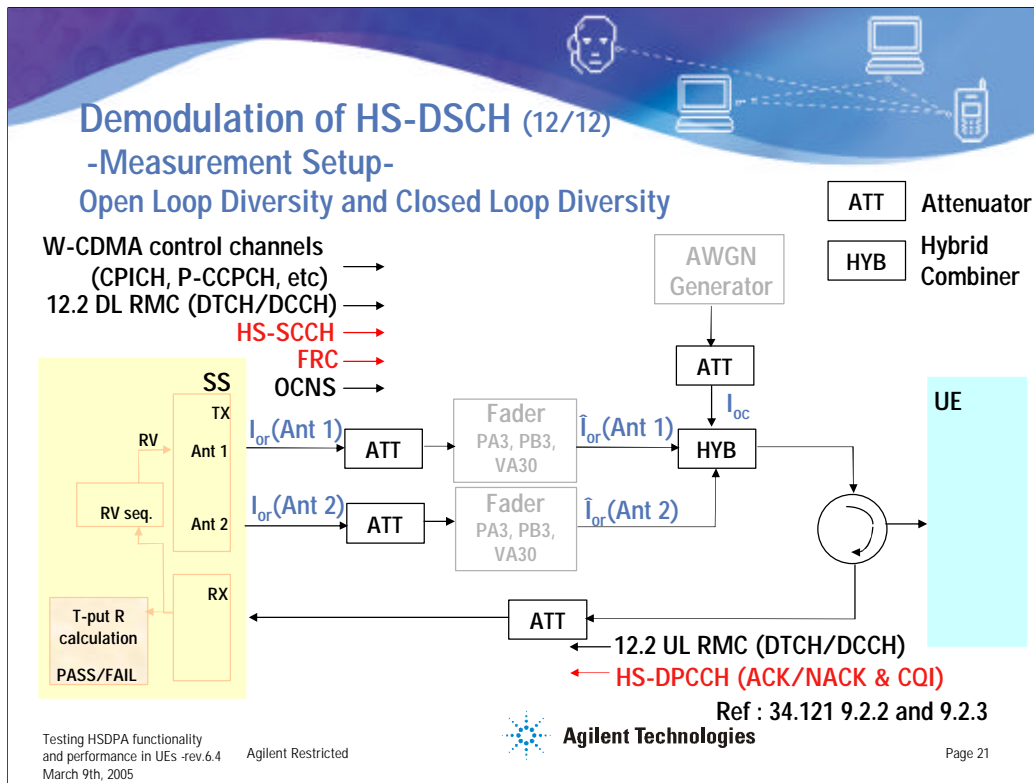

The HS-DSCH demodulation/decoding performance of the UE must also be evaluated under open loop and closed loop diversity scenarios. Diversity modes are part of the W-CDMA system, so they are not HSDPA additions. But the HSDPA performance will vary from single link scenarios, so different test settings and minimum requirements are given for diversity conditions.

Use of diversity modes, in the most general statement, provides a means for the UE to realize signal quality gains over the standard transmission of a single channel to the UE.

Open loop diversity is optional for the W-CDMA Node-B but mandatory for the UE. This mode sends the DPCH to the UE from two antenna elements on the tower, with the second element transmitting a DPCH that is inverted and interleaved differently from that transmitted on the primary cell. Upon reception, if a discrete time fade occurs, the data from the two antennas will be different (since the diversity antenna sends the symbols in different order). This form of interleaving thus aids reception since recovery of the lost symbol can occur on one of the antennas. The seemingly small difference in distance between the two antenna elements can give several dB of gain at the UE.

In closed loop transmit diversity, the UE constantly evaluates what combination of received signal phase or phase and amplitude from both antennas will provide the best gain, and instructs the cell to make changes, real time, to the transmissions as the UE moves through the network.

As for testing, the conformance test measurement setup is similar to the single link case, but the SS must be able to simulate a cell with a normal and a diversity antenna. Two faders (one for each antenna) are required.

The uplink connection does not change, except in the close loop mode, in which the SS must be able to respond to the close loop link instructions from the UE.



**Which of the following statements about FRCs are correct?**

- The coding and modulation configurations for an FRC are fixed, except for the RV
- There are 5 different FRC H-Sets in Release 5. Which one to use depends on the UE category
- Each FRC H-Set configuration uses a certain fixed RV
- Each FRC H-Set configuration has a fixed nominal average information bit rate

Testing HSDPA functionality and performance in UEs -rev.6.4  
March 9th, 2005

Agilent Restricted

 **Agilent Technologies**

Page 22

Information about the Q&A:

Which of the following statements about FRCs are correct?

The coding and modulation configurations for an FRC are fixed, except for the RV

**True.** All the coding and modulation parameters are fixed, except for the RV, which can vary for retransmissions.

There are 5 different FRC H-Sets in Release 5. Which one to use depends on the UE category

**True.** There are 5 FRC H-Sets in Release 5 and 6 FRC H-Sets in Release 6. Each UE category is assigned a certain FRC H-Set. FRC H-Set 1 is used to test UE categories 1 and 2. FRC H-Set 2 is used to test UE categories 3 and 4. FRC H-Set 3 is used to test categories 5 and 6. FRC H-Set 4 is used to test category 11. FRC H-Set 5 is used to test category 12. FRC H-Set 6 (Release 6) is used to test categories 7 and 8.

Each FRC H-Set configuration uses a certain fixed RV

**False.** The RV is the only parameter that is not specified in the FRC definition. The RV changes for retransmissions. The RV (or the RV sequence) to use is part of the specified test parameters. For the Demodulation of HS-DSCH test, the specified RV sequence depends on whether a QPSK configuration or a 16QAM configuration is used.

Each FRC H-Set configuration has a fixed nominal average information bit rate

**True.** The nominal average information bit rate is one of the parameters that is specified for a certain FRC H-Set configuration. The nominal average information bit rate is also directly determined by the transport block size and the number of HARQ processes defined for that FRC H-Set configuration.



**If BLER is known, which of the following aspects about the FRC that was used for the test do you need to know to calculate t-put R?:**

- The nominal information bit rate for an active TTI and the modulation scheme
- The nominal average information bit rate
- The nominal information bit rate for an active TTI and the number of processes
- The nominal information bit rate for an active TTI and the virtual IR buffer size per process

Testing HSDPA functionality and performance in UES -rev.6.4 March 9th, 2005      Agilent Restricted       **Agilent Technologies**      Page 23

Information about the Q&A:

If BLER is known, which of the following aspects about the FRC that was used for the test do you need to know to calculate t-put R?:

The nominal information bit rate for an active TTI and the modulation scheme

False. None of these two parameters take into account the number of processes defined for that FRC, so the nominal average information bit rate cannot be calculated.

The nominal average information bit rate

True. Throughput  $R = (1 - \text{BLER}) \times \text{nominal average information bit rate}$ .

The nominal information bit rate for an active TTI and the number of processes

True. The nominal average information bit rate needed to calculate throughput R from BLER is the same as the nominal information bit rate for an active TTI  $\times$  (number of processes/6). So, for an FRC H-Set configuration, the nominal average information bit rate = (information bit payload/2 ms)  $\times$  (number of processes/6).

The nominal information bit rate for an active TTI and the virtual IR buffer size per process

False. These parameters do not provide information on the number of processes used, which is necessary to calculate the nominal average information bit rate.

## Agenda

### UE Performance Requirements Test Setups

### Performance Requirements Tests

- Demodulation of HS-DSCH (34.121 9.2)
- Reporting of CQI (34.121 9.3)
  - AWGN Propagation Conditions (34.121 9.3.1)
  - Fading Propagation Conditions (34.121 9.3.2)
- HS-SCCH Detection Performance (34.121. 9.4)

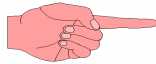

### Other Non-Conformance Tests

### Agilent Solutions

### Summary

Testing HSDPA functionality  
and performance in UES -rev.6.4  
March 9th, 2005

Agilent Restricted



Page 24

The Reporting of CQI tests (34.121. 9.3) will be discussed next. There are two different tests under this section: the AWGN propagation conditions test (34.121. 9.3.1) and the Fading propagation conditions test (34.121 9.3.2). Although their purpose is similar, there are some differences in their test procedures. The following section covers both tests.



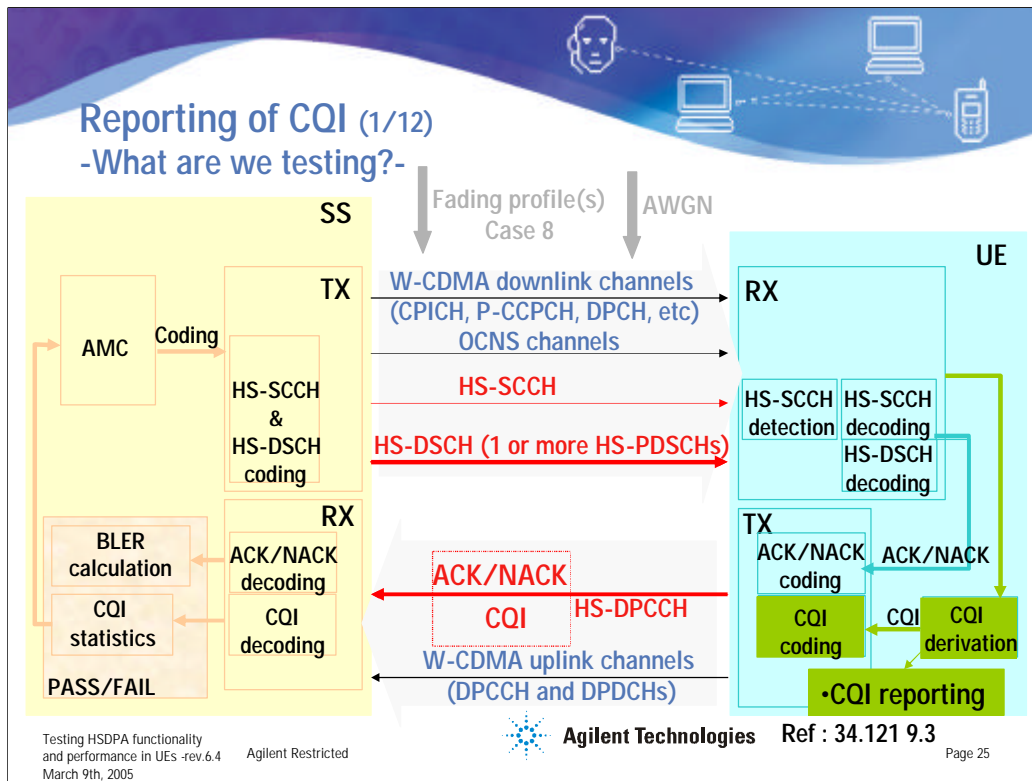

The Reporting of CQI tests evaluate the accuracy of the CQI reporting under different AWGN and fading conditions. The CQI reporting function mainly consists of the CQI derivation algorithm and the CQI coding.

The test setup for the Reporting of CQI tests is similar to the setup for the Demodulation of HS-DSCH test, except that the HS-DSCH is not configured as an FRC. Using FRCs does not make sense in this case, since CQI reporting is part of the AMC link adaptation technique, in which the modulation and coding of the transmitted HS-DSCH changes as a function of the reported CQI.

There are two different parameters used to evaluate the accuracy of the reporting: the variance of the reported CQI, and the BLER performance when using the coding parameters indicated by the reported CQI median. The HS-DSCH is first configured according to a CQI value of 16 to study the variance of the reported CQI. Then, the HS-DSCH is configured according to the reported CQI median (+/- 1 or 2) and the BLER (calculated from the ACK/NACK report) is measured to ensure that the performance of the CQI reporting falls within the expected range. No retransmissions are allowed for this test. More detailed test procedures for both the AWGN propagation conditions and the Fading propagation conditions tests will be explained in the following slides.

As with the Demodulation of HS-DSCH test, In addition to the HS-DSCH, the SS must transmit the associated HS-SCCH, and all the W-CDMA downlink channels required to establish and maintain a connection. The channel configuration for the DPCH corresponds to the RMC 12.2 kbps. Refer to 34.121 section E.5.1 for more information on the configuration for the downlink physical channels. 6 OCNS channels are also transmitted to account for the energy transmitted to other users in a real BTS (see 34.121 section E.5.2).

While the AWGN propagation conditions test must only be performed under AWGN conditions, the Fading propagation conditions test must be performed both under multi-path fading and under AWGN conditions. The multi-path fading profile for the Fading propagation conditions test corresponds to Case 8, which consists of 2 paths. This fading profile is only used for the Reporting of CQI test. Refer to 25.101 section B.2.2 table B.1C for more details on this fading profile.



## Reporting of CQI (2/12) -AWGN Propagation Conditions (Part 1)-

**Part 1.**

**Purpose: To verify that the CQI reporting variance under AWGN is within certain limits**

# HARQ transmissions=1 (no retransmissions); HS-DSCH coding fixed based on CQI=16

1. Send 2000 blocks and record the received CQI
2. Create a CQI frequency distribution and calculate the median-CQI value
3. If 1800 or more CQI values are within the range  
 $(\text{Median-CQI} - 2) = \text{Median-CQI} = (\text{Median-CQI} + 2)$   
 then follow part 2., otherwise fail the UE

**Ref : 34.121 9.3.1.4.2**

Testing HSDPA functionality and performance in UEs -rev.6.4  
March 9th, 2005

 **Agilent Technologies**

Page 26

First, the CQI reporting under AWGN propagation conditions test will be explained. There are two parts in the AWGN propagation conditions test. The first part of the procedure will first be discussed.

During the first part of the procedure, the HS-DSCH is set up with the coding parameters corresponding to CQI=16. The ACK/NACK report is disregarded and no retransmissions are allowed. 2000 blocks are transmitted and the CQI values reported by the UE are recorded. A frequency distribution is created to evaluate the variance of the reported CQI. To pass this first part of the test, the reported CQI value must be within the range of +/-2 of the reported CQI median (median-CQI) 90% of the time (i.e. 1800 or more of the reported CQI values must lie within the median-CQI-2 value and the median-CQI+2 value).

## Reporting of CQI (3/12)

### -CQI Value Derivation Procedure in UE-

Example: Coding parameters from CQI table for UE categories 1 to 6

Virtual IR buffer size

CQI Value	Transport block size	Number of HS-PDSCH	Modulation	Reference power adjustment D dB	$N_{IR}$	RV
0	Out of range					
1	137	1	QPSK	0	9600	0
15	3319	5	QPSK	0	9600	0
16	3565	5	16QAM	0	9600	0
29	7168	5	16QAM	-7	9600	0
30	7168	5	16QAM	-8	9600	0

**Configurations based on reported CQI or lower value should provide BLER =0.1**

Ref : 25.214 6.A.2 and Tables 7A-E

Testing HSDPA functionality and performance in UES -rev.6.4  
March 9th, 2005

Agilent Restricted

**Agilent Technologies**

Page 27

In order to understand the meaning of the Reporting of CQI tests, it is useful to review the CQI value derivation procedure in the UE and the meaning of the CQI value.

The CQI can take values from 0 to 30. There are CQI mapping tables (25.214 Table 7A,...E), depending on the UE category, that link the CQI values to certain coding and modulation parameters. The slide shows a portion of the table 7A in 25.214, which corresponds to UE categories 1 to 6. For a certain category, each CQI value corresponds to a certain transport block size, a certain number of HS-PDSCHs, either QPSK or 16 QAM modulation, and a reference power adjustment ? (except for CQI=0, which denotes out-of-range conditions). Higher CQI values denote better link conditions, so these CQI values typically correspond to larger transport block sizes, larger numbers of HS-PDSCHs, 16QAM, and larger reference power adjustments.

To derive the CQI value, the UE assumes a certain virtual IR buffer size  $N_{IR}$ , which depends on the UE category. It also assumes that the RV used is 0 and a certain value for the total received HS-PDSCH power, based on the power of the received CPICH, the measurement power offset G signalled by higher layers and on the reference power adjustment ? (see 25.214 6.A.2 for more details).

The transport block size, number of HS-PDSCHs, and the modulation scheme define the effective coding and modulation of the HS-DSCH. The UE reports the maximum CQI value from the table for its UE category that corresponds to coding configurations that should provide BLER equal or lower than 0.1, assuming a certain  $N_{IR}$ , RV, and total received HS-PDSCH power. For example, if a CQI value of 16 is reported, the UE is telling the BTS that it should be able to receive and decode any configurations corresponding to CQI values 16 or lower with a BLER better than 0.1, under the aforementioned assumptions and present channel conditions.

As mentioned earlier, during the first part of the Reporting of CQI under AWGN propagation conditions test, the HS-DSCH is arbitrarily configured with the coding parameters corresponding to CQI value 16, and the coding does not change with the reported CQI (so AMC is not applied). For UE categories 1 to 6, CQI value 16 corresponds to a transport block size of 3565 bits, 5 HS-PDSCHs, 16 QAM modulation, ? =0,  $N_{IR}$ =9600 bits, and RV=0.

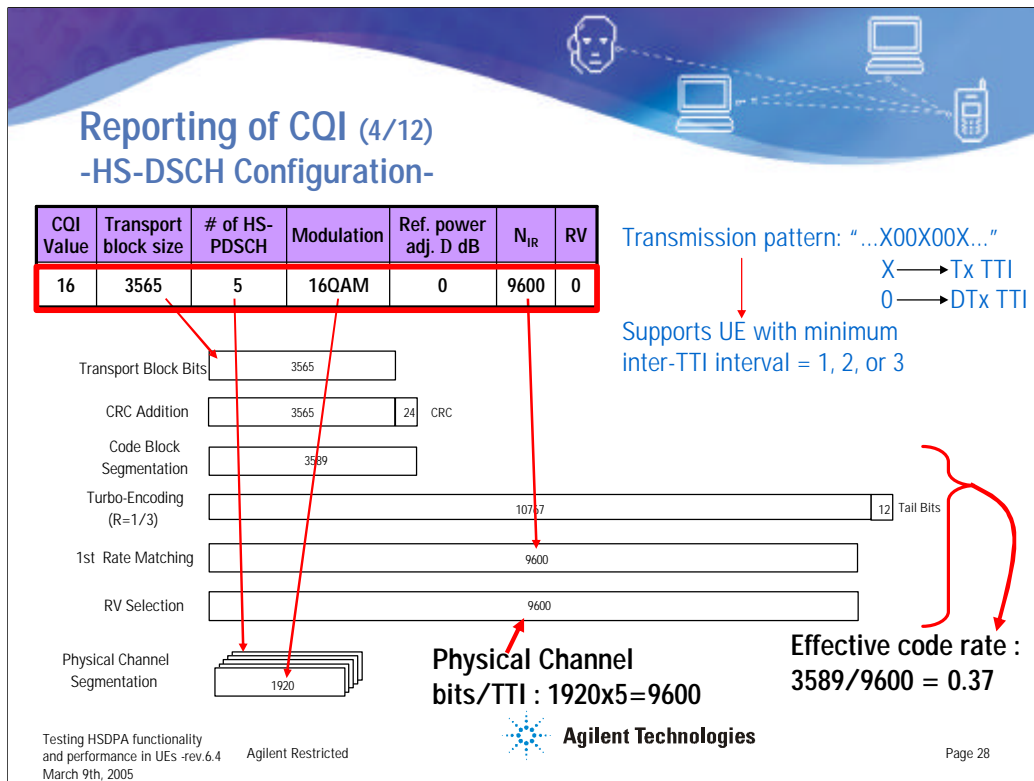

If the transport block size, the number of HS-PDSCHs, and the modulation scheme are known, the number of physical channel bits and the effective coding for the HS-DSCH can be determined, as shown earlier in the presentation. The same three parameters, along with  $N_{IR}$  and the RV parameter, define the whole HS-DSCH coding.

The HS-DSCH coding corresponding to CQI=16 is shown in the slide. Again, this is the HS-DSCH channel configuration during the first part of the Reporting of CQI under AWGN propagation conditions test.

The HS-DSCH TTI transmission pattern for this test is defined as "...X00X00X..." (2 parallel processes) to accommodate UEs with minimum inter-TTI interval = 3. UEs with minimum inter-TTI interval = 1 or 2 can also support this pattern. Note that the maximum number of parallel processes that UEs with minimum inter-TTI interval = 1 or 2 support is higher than 2. However, for the Reporting of CQI test, it is not necessary to stress the minimum inter-TTI interval capability of the UE, since this capability is part of the UE's HS-DSCH decoding performance, which is not of concern for this test.

## Reporting of CQI (5/12)

### -CQI Coding-

CQI value	→	$a_4 \dots a_0$	→	$b_0 \dots b_{19}$	→	PhCH
0	→	00001	→	1...0		
1	→	00010	→	0...0		
⋮	→	⋮	→	⋮		
30	→	11111	→	0...1		
(decimal)		(binary)		(binary)		

```

graph TD
    CQI[CQI] --> CC[Channel Coding]
    CC --> PCHM[Physical channel mapping]
    PCHM --> PhCH[PhCH]
    
```

↑

**CQI mapping**  
TS.25.214  
Tables 7A-E

↑

**Decimal CQI**  
value 0...30  
correspond to  
CQI bits  
{00001} to  
{11111}

↑

**Conversion using a**  
(20,5) code,  
TS.25.212 Table 14

Ref : 25.212 4.7.1.2

Testing HSDPA functionality and performance in UEs -rev.6.4 March 9th, 2005

Agilent Restricted

Agilent Technologies

Page 29

Until now, the CQI value derivation procedure in the UE and the relationship between a CQI value and the corresponding HS-DSCH coding configuration has been reviewed. This slide illustrates the CQI coding process in the UE.

The CQI takes values 0,1,2,...,30, as defined in one out of 5 CQI mapping tables depending on the UE category. The CQI values are converted from decimal to binary and mapped onto the CQI bits ( $a_4 a_3 a_2 a_1 a_0$ ) respectively. Note that (00001) corresponds to 0, not 1. And (11111) corresponds to 30, not 31.

The 20-bit-long binary encoded CQI word  $b_0 \dots b_{19}$  results from coding the CQI bits  $a_4 \dots a_0$  using a (20,5) sequence table (see 25.212 Table 14). The purpose of this coding is to add redundancy to the 5-bit-long CQI bits. The first 10 bits of the CQI word are mapped onto slot #1 of the HS-DPCCH, and the other 10 bits are mapped onto slot #2.

## Reporting of CQI (6/12) -CQI Decoding-

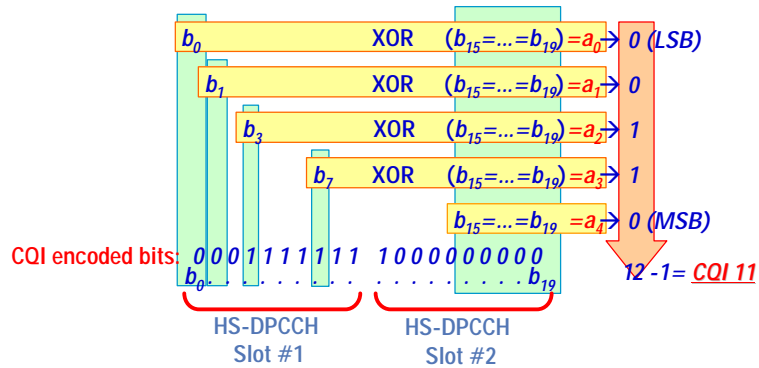

Testing HSDPA functionality  
and performance in UEs -rev.6.4  
March 9th, 2005

Agilent Restricted

 Agilent Technologies

Page 30

During the first part of the Reporting of CQI under AWGN propagation conditions test, the HS-DSCH TF (corresponding to CQI=16) is fixed and 2000 blocks are sent to the UE. The CQI values reported back from the UE must be decoded and collected in order to calculate the reported CQI value statistics. The CQI decoding takes place in the SS as part of the conformance test procedure in the specifications.

During the coding, the CQI values 0...30 are converted to (00001) to (11111) and the 5-digit CQI bits are coded into a 20-bit-long binary encoded CQI word  $b_0 \dots b_{19}$ . So, the decoding process must first decode the 5-digit CQI bits from the 20-bit long CQI word, and then convert the 5-digit CQI bits back to the decimal CQI values. This slide shows a manual CQI decoding example to extract CQI decimal values from the measured CQI code word bits  $b_0 \dots b_{19}$ . For simplicity, error correction during the decoding process from 20 to 5 bits is not taken into account in the slide.

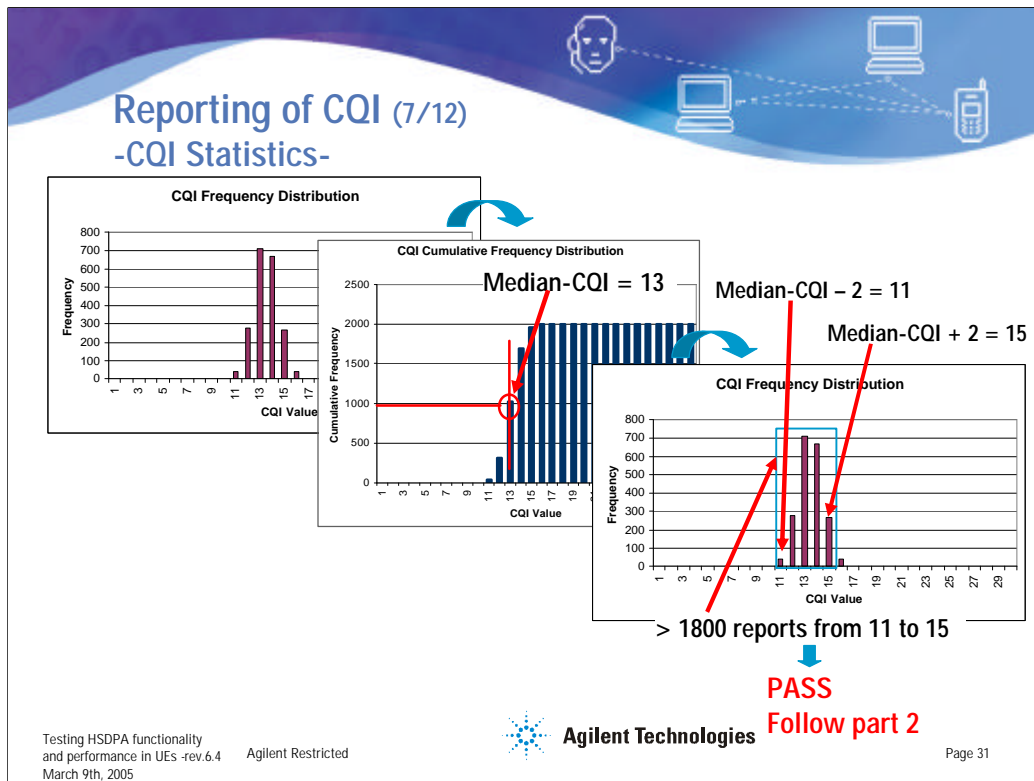

Once 2000 reported CQI values have been received from the UE and decoded, the frequency distribution of the reported CQI value must be analyzed. For stable conditions, the variance of the CQI report must be within certain limits. Out of 2000 CQI values, more than 1800 must fall within a range of 5 CQI consecutive values (from a value of (median CQI - 2) to a value of (median CQI + 2)).

The slide shows an example of the frequency distribution for 2000 CQI values. The reported CQI median (median-CQI) can be determined by creating the CQI cumulative frequency distribution and determining the CQI value that corresponds to 50% (1000 samples) of the cumulative frequency. In other words, 50% of the time, the CQI value is below or at the median and 50% of the time the CQI value is above the median. For example, in this case the median is 13 (50% of the time the CQI value is below or at 13). Once the median is calculated, the CQI frequency distribution can be examined again to determine whether the CQI value variance is within the expected limits. In this case, most of the CQI values fall between 11 and 15, so the UE would pass the first part of the test.

The graphic in this slide has been created as an example and it is not representative of real UE behavior.

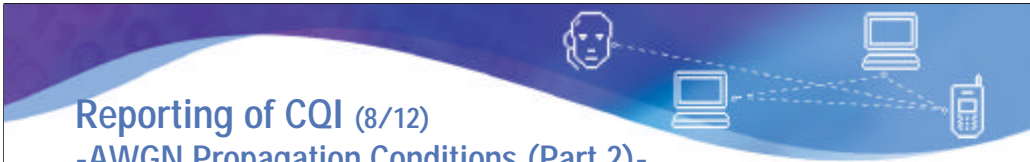

## Reporting of CQI (8/12) -AWGN Propagation Conditions (Part 2)-

**Part 2.**

**Purpose: To verify that the BLER performance for the reported CQI median falls within the expected range and has the correct sense.**

# HARQ transmissions=1 (no retransmissions); fixed HS-DSCH configuration

1. Configure HS-DSCH based on median-CQI and calculate BLER for 1000 blocks
2. If  $BLER < 0.1$  ( $< 10\%$ ),  
then configure HS-DSCH based on median-CQI+2 and calculate BLER for 1000 blocks.  
If  $BLER > 0.1$  ( $> 10\%$ ) then PASS, otherwise FAIL
3. If  $BLER > 0.1$  ( $> 10\%$ ),  
then configure HS-DSCH based on median-CQI-1 and calculate BLER for 1000 blocks.  
If  $BLER < 0.1$  ( $< 10\%$ ) then PASS, otherwise FAIL

**Ref : 34.121 9.3.1.4.2**

Testing HSDPA functionality and performance in UES -rev.6.4 March 9th, 2005      Agilent Restricted



Page 32

As mentioned earlier, the objective for the CQI value derivation procedure in the UE is to report the maximum CQI value whose corresponding coding configuration would provide a BLER that would not exceed 0.1 (10%) for the present channel conditions. The purpose of the second part of the Reporting of CQI under AWGN propagation conditions test is to verify that the BLER performance for the HS-DSCH coding configuration based on the reported CQI median falls within the expected range and has the correct sense.

For this part of the test, the HS-DSCH is configured with a configuration that corresponds to the median-CQI value calculated in the first part of the test. The coding is fixed, which means that the coding parameters do not change with the reported CQI. No retransmissions are allowed, but the ACK/NACK reports for 1000 blocks are used to calculate BLER.

There are two possible scenarios:

- If BLER is lower than 0.1, the HS-DSCH is configured based on a value of median-CQI+2 and BLER is calculated for another 1000 blocks. The purpose here is to verify that the median-CQI value reported by the UE is (or is very close to) the maximum CQI value that would meet the BLER requirement. So, in this case, if BLER is higher than 0.1, the UE passes the test. Otherwise, it fails the test, since the UE reported CQI values could probably be higher and still meet the BLER requirements.

- If BLER is higher than 0.1 (for the HS-DSCH configuration based on the median-CQI value), the HS-DSCH is configured based on a value of median-CQI-1. The purpose here is to verify that, even though the BLER is higher than 0.1 for an HS-DSCH configuration based on the median-CQI value, this value is very close to meeting the BLER requirements. So, if the coding configuration corresponding to the immediately lower CQI value results in a BLER lower than 0.1, the UE passes the test, since the CQI reporting is behaving within the expected range. Otherwise, it fails the test.



## Reporting of CQI (9/12) -Sense of BLER-

$$BLER = \frac{(NACK + statDTX)}{(NACK + statDTX + ACK)}$$

	0.2	0.4	
Example 1:	PASS ← 0.09	0.08	0.4 → PASS
Example 2:	0.2	0.04	0.09 → FAIL
Example 3:	0.08	0.3	
Example 4:	FAIL ← 0.2		

HS-DSCH  
coding  
based on  
median-  
CQI-1

HS-DSCH  
coding  
based on  
median-  
CQI

HS-DSCH  
coding  
based on  
median-  
CQI+2

CQI ↑

Testing HSDPA functionality and performance in UES -rev.6.4 March 9th, 2005
Agilent Restricted
Page 33

For the Reporting of CQI under AWGN propagation conditions test, as for the Demodulation of HS-DSCH test, BLER is defined as the ratio of unsuccessfully received and decoded blocks to the total number of information blocks sent. So, BLER is equal to  $(NACK + statDTX) / (NACK + statDTX + ACK)$  as shown the slide.

As mentioned before, this second part of the test verifies the correct sense of BLER for the CQI reporting. The general idea is that BLER should be noticeably worse (than the BLER for HS-DSCH configuration based on median-CQI) for the configuration based on median-CQI+2 (coding parameters set up for better reported channel conditions) and noticeably better for the configuration based on median-CQI-1.

The slide shows four different test scenarios. In the first example, the BLER for the HS-DSCH configuration based on median-CQI value is higher than 0.1 (0.2), but the BLER for the configuration based on the median-CQI-1 value is lower than 0.1 (0.09), so the UE passes the test.

In the second example, the BLER for the HS-DSCH configuration based on the median-CQI value is lower than 0.1 (0.08) and the BLER is noticeably worse (0.4) for the HS-DSCH configuration based on a median-CQI+2 value. So, the UE also passes the test.

In the third example, the BLER for the HS-DSCH configuration based on the median-CQI value is lower than 0.1 (0.04), but the BLER is also lower than 0.1 for the configuration based on a median-CQI+2 value. So, the median-CQI value does not fall within the expected range (it should be higher) and the UE fails the test.

In the fourth example, the BLER for the HS-DSCH configuration based on the median-CQI value is higher than 0.1 (0.3), and the BLER for the configuration based on the median-CQI-1 value is not as low as expected (0.2). So, the median-CQI value does not fall within the expected range (it should be lower) and the UE fails the test.



## Reporting of CQI (10/12) -Fading Propagation Conditions-

**Purpose: To verify the CQI reporting accuracy under fading environments**

# HARQ transmissions=1 (no retransmissions); fixed HS-DSCH configuration

1. Configure HS-DSCH based on CQI=16 and record the received CQI for 2000 blocks
2. Calculate the median-CQI value
3. Configure HS-DSCH based on the median-CQI and continue to transmit blocks
4. Calculate BLER (based on ACK/NACK, discard DTX) for 1000 blocks (DTX blocks not included) with corresponding reported CQI=median-CQI (Event R1)
5. Calculate BLER (based on ACK/NACK, discard DTX) for 1000 blocks (DTX blocks not included) with corresponding reported CQI=median-CQI + 3 (Event R2)
6. BLER should be < 60% for step 4 (R1) and <15% for step 5 (R2).

Testing HSDPA functionality and performance in UEs -rev.6.4 March 9th, 2005      Agilent Restricted       **Agilent Technologies**      Ref : 34.121 9.3.2.4.2      Page 34

The purpose of the Reporting of CQI under fading propagation conditions test is to verify the CQI reporting accuracy under fading environments.

For this test, the HS-DSCH is configured based on CQI=16. The coding parameters do not change with the reported CQI value (so, no AMC is applied). The ACK/NACK report is disregarded and no retransmissions are allowed. 2000 blocks are transmitted and the CQI values reported by the UE are recorded. A frequency distribution is created and the median-CQI value is calculated, in the same way that it is calculated for the first part of the AWGN propagation conditions test.

Then the HS-DSCH is configured based on the calculated median-CQI value and no retransmissions are allowed. The coding parameters do not change with the reported CQI value (so, no AMC is applied). The BLER is calculated for two different events:

-Event R1: calculate the BLER (based on ACK/NACK report, and discarding DTX responses) for 1000 blocks (DTX blocks are not included) with corresponding reported CQI equal to the median-CQI calculated earlier. The BLER should be lower than 60% to pass this part of the test.

-Event R2: calculate the BLER (based on ACK/NACK report, and discarding DTX responses) for 1000 blocks (DTX blocks are not included) with corresponding reported CQI equal to the median-CQI+3 calculated earlier. The BLER should be lower than 15% to pass this part of the test.

The meaning of these two events is explained in more detail in the next slide.

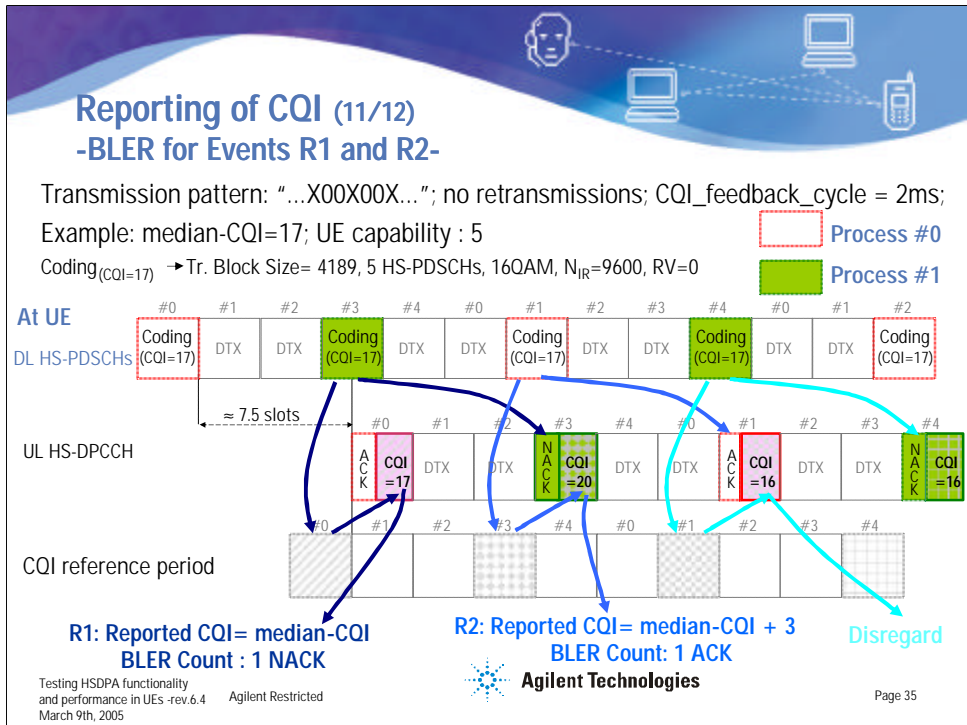

This slide shows an example of the procedure to calculate BLER for events R1 and R2.

As with the AWGN propagation conditions test, the HS-DSCH TTI transmission pattern for this test is defined as "...X00X00X..." to accommodate UEs with minimum inter-TTI interval=3 (and lower). Two parallel processes must be used to support this pattern. The CQI feedback cycle is 2 ms, so a CQI report is sent for every active HS-DSCH subframe received.

In this example, the UE capability is 5. The calculated median-CQI value is 17, which corresponds to a transport block size=4189, 5 HS-PDSCHs, 16 QAM, N<sub>IR</sub>=9600 bits and RV=0.

The key to understanding this test lies in understanding the CQI definition (see 25.214 6A.2). According to this definition, the CQI is derived for a 3-slot reference period ending 1 slot before the start of the first slot in which the reported CQI value is transmitted. The CQI reference periods for the CQI reports in this example are highlighted in different patterns at the bottom of the slide. The associated HS-PDSCH subframes are the subframes that start during these reference periods. Each HS-PDSCH subframe, its corresponding CQI reference period, and the corresponding CQI report for that reference period, are all linked through arrows in the slide. The ACK/NACK report corresponding to the HS-PDSCH subframe is also linked to that HS-PDSCH subframe with an arrow.

Event R1 occurs every time the reported CQI associated to a certain HS-PDSCH block has the same value as the previously calculated median-CQI (17 in this case). The ACK/NACK report must be collected for 1000 of these events, and the BLER must be calculated. DTX reports are discarded, so the BLER in this case is defined as NACK/(ACK+NACK).

Event R2 occurs when the reported CQI corresponding to a certain HS-PDSCH block has the same value as the previously calculated median-CQI+3 (20 in this case). The ACK/NACK report must be collected for 1000 of these events, and the BLER must be calculated. DTX reports are discarded, so the BLER in this case is defined as NACK/(ACK+NACK).

If the CQI value corresponding to a certain HS-PDSCH block is not equal to either median-CQI or median-CQI+3, the corresponding ACK/NACK report is disregarded, since it does not belong to either event R1 or event R2.

The minimum requirements for this test (BLER < 60% for R1 and BLER < 15% for R2) are set on the expectation that the BLER for event R2 will be much lower than the BLER for event R1, since the blocks associated with R2 are received during better link conditions, according to the CQI report (the reported CQI value for event R2 is higher than the reported CQI value for event R1).

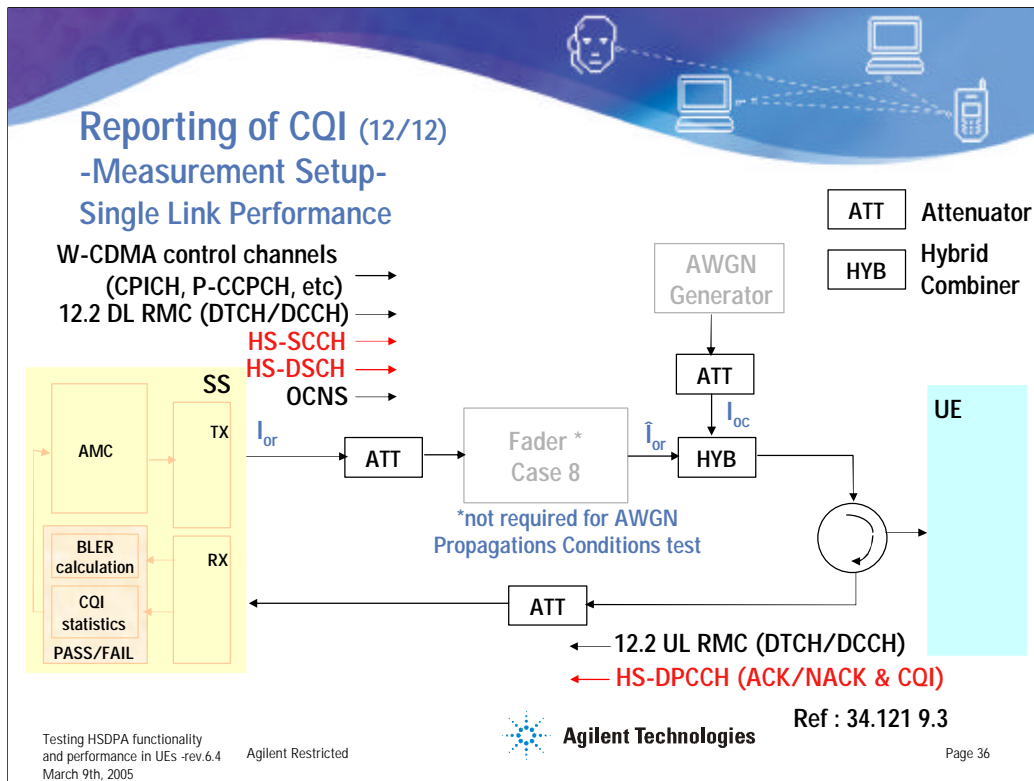

The generic connection diagram for the Reporting of CQI tests is shown above. Fading profiles and AWGN might be provided by the system simulator itself, or if not available, by external faders and AWGN sources. Note that fading is not required for the AWGN propagation conditions test. Both AWGN and fading are required for the Fading propagation conditions test.

An HSDPA call must be first set up, and the test conditions and test parameters must be set as described in 34.121 section 9.3.1 (for the AWGN propagation conditions test) and 9.3.2 (for the Fading propagation conditions test). The actual test parameters depend on the UE category. The test is repeated for the different test parameters.

Note that the AMC functionality in the SS is only used to set up a fixed HS-DSCH configuration according to different CQI values, during the different parts of the tests. Initially the HS-DSCH is configured according to CQI value 16, next the HS-DSCH is configured according to the calculated median-CQI value, and for the AWGN propagations conditions test, the HS-DSCH might be configured according to either median-CQI+2 or median-CQI-1, depending on the intermediate test results. So, the SS does not directly react to the reported CQI, during the different parts of the tests.

Even though the Release 5 conformance test specifications only describe the single link scenario for the Reporting of CQI tests, the Release 6 specifications will include open loop diversity and closed loop diversity scenarios (see 25.101 version 6.4.0 section 9.3). This presentation is based on Release 5 and only includes the connection setup for the single link performance tests. The connection setup for the diversity cases will probably be similar to the connection setup for the Demodulation of HS-DSCH, open loop diversity and closed loop diversity performance tests, shown earlier in the presentation.



**Which of the following statements about CQI reporting is true?**

- High CQI values indicate good channel conditions and are linked to large transport block sizes
- High CQI values indicate bad channel conditions and are linked to large transport block sizes
- High CQI values indicate good channel conditions and are linked to small transport block sizes
- High CQI values indicate bad channel conditions and are linked to small transport block sizes

Testing HSDPA functionality and performance in UES -rev.6.4 March 9th, 2005      Agilent Restricted       Agilent Technologies      Page 37

Information about the Q&A:

Which of the following statements about CQI reporting is true?

High CQI values indicate good channel conditions and are linked to large transport block sizes

**True.** High CQI values indicate good instantaneous channel conditions. In other words, high CQI values indicate that HS-DSCH configurations with large transport block sizes (high data rates), 16 QAM, and a large number of HS-PDSCHs can be used with acceptable error rates under those conditions.

High CQI values indicate bad channel conditions and are linked to large transport block sizes

**False.** It does not make sense to use large transport block sizes (high data rates) when the channel conditions are bad.

High CQI values indicate good channel conditions and are linked to small transport block sizes

**False.** It does not make sense to use small transport block sizes (low data rates) when the channel conditions are good.

High CQI values indicate bad channel conditions and are linked to small transport block sizes

**False.** High CQI values indicate good channel conditions.



**Under stable channel conditions, we expect the variance of the reported CQI value to be...**

- Large
- Small
- We do not care about the CQI variance, under stable conditions
- If the median-CQI value is low, we want a small variance. If the median-CQI value is high, we want a large variance

Testing HSDPA functionality and performance in UES -rev.6.4 March 9th, 2005      Agilent Restricted       **Agilent Technologies**      Page 38

Information about the Q&A:

Under stable channel conditions, we expect the variance of the reported CQI value to be...

Large

**False.** The reported CQI provides an indication on the channel conditions, so ideally it should not vary much if the channel conditions are stable.

Small.

**True.** The reported CQI provides an indication on the channel conditions, so ideally it should not vary much if the channel conditions are stable.

We do not care about the CQI variance, under stable conditions

**False.**

If the median-CQI value is low, we want a small variance. If the median-CQI value is high, we want a large variance

**False.**



**The purpose of the second part of the AWGN propagation conditions test procedure is...**

- To verify that the UE is capable of decoding an HS-DSCH configured according to median-CQI.
- To verify that the median-CQI is close to the maximum CQI value, whose corresponding HS-DSCH configuration would provide acceptable BLER results under the present channel conditions
- To verify that the median-CQI is close to the minimum CQI value, whose corresponding HS-DSCH configuration would provide acceptable BLER results under the present channel conditions.

Testing HSDPA functionality and performance in UEs -rev.6.4 March 9th, 2005      Agilent Restricted       **Agilent Technologies**      Page 39

Information about the Q&A:

The purpose of the second part of the AWGN propagation conditions test procedure is...

To verify that the UE is capable of decoding an HS-DSCH configured according to median-CQI.

**False.** This is not the objective. We are not really concerned about the HS-DSCH decoding during this test. What we want to ensure is that the CQI reporting is accurate.

To verify that the median-CQI is close to the maximum CQI value, whose corresponding HS-DSCH configuration would provide acceptable BLER results under the present channel conditions

**True.** We want to make sure that the UE is providing an accurate CQI report to the BTS. So, we want to ensure that the reported CQI median is close to the maximum CQI that could be reported.

To verify that the median-CQI is close to the minimum CQI value, whose corresponding HS-DSCH configuration would provide acceptable BLER results under the present channel conditions.

**False.** We want to make sure that the UE is providing an accurate CQI report to the BTS. So, we want to ensure that the reported CQI median is close to the maximum CQI that could be reported.



**Regarding the fading propagation conditions test, event R1 is associated with a higher BLER than event R2 because...**

- The DTX reports are disregarded.
- The HS-DSCH blocks associated with event R2 are received during better channel conditions.
- The HS-DSCH blocks associated with event R2 are received during worse channel conditions
- There is no reason for the difference in BLER. The BLER requirements for these two events are arbitrary.

Testing HSDPA functionality and performance in UES -rev.6.4 March 9th, 2005      Agilent Restricted       **Agilent Technologies**      Page 40

Information about the Q&A:

Regarding the fading propagation conditions test, event R1 is associated with a higher BLER than event R2 because...

The DTX reports are disregarded.

**False.** The fact that the DTX reports are disregarded does not have anything to do with the fact that the BLER minimum requirement for event R1 is higher than for event R2.

The HS-DSCH blocks associated with event R2 are received during better channel conditions.

**True.** When the HS-DSCH blocks associated with event R2 are received, the channel conditions are measured and the resulting CQI is median-CQI+3, which indicates better channel conditions than median-CQI (resulting CQI when HS-DSCH blocks associated with event R1 are received).

The HS-DSCH blocks associated with event R2 are received during worse channel conditions

**False.** See explanation above.

There is no reason for the difference in BLER. The BLER requirements for these two events are arbitrary.

**False.** See explanation above.



## Agenda

### UE Performance Requirements Test Setups

#### Performance Requirements Tests

- Demodulation of HS-DSCH (34.121 9.2)
- Reporting of CQI (34.121 9.3)
  - AWGN Propagation Conditions (34.121 9.3.1)
  - Fading Propagation Conditions (34.121 9.3.2)
- HS-SCCH Detection Performance (34.121. 9.4)

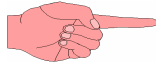

#### Other Non-Conformance Tests

#### Agilent Solutions

#### Summary

Testing HSDPA functionality  
and performance in UES -rev.6.4  
March 9th, 2005

Agilent Restricted



Page 41

Next, the HS-SCCH detection performance test (34.121 9.4) will be explained.

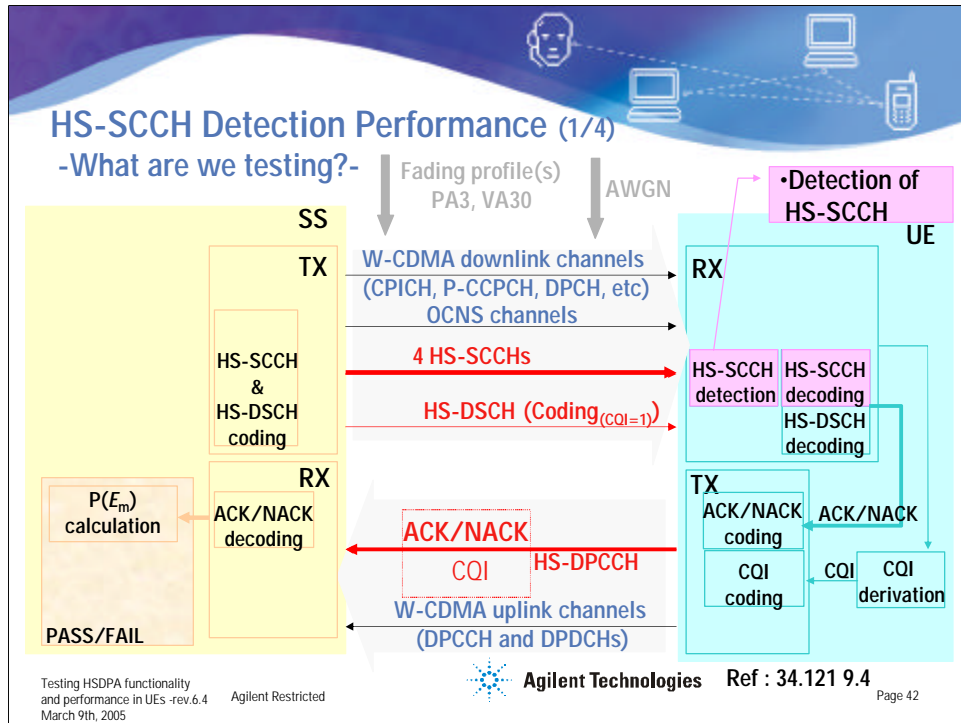

The purpose of the Detection of HS-SCCH test is to ensure that the UE is capable of correctly recognizing when it is being signaled by an HS-SCCH.

Four HS-SCCHs are sent to the UE, each with a different UE identity. The only purpose of this is to ensure that the UE can recognize the signaling from the only HS-SCCH that is intended for it (HS-SCCH1). Only one HS-DSCH is left active, while the HS-DSCH associated to the other three HS-SCCH are DTX.

For this test, the HS-DSCH demodulation and decoding performance and the CQI reporting performance of the UE are not of concern. No retransmissions are allowed and the CQI report is disregarded. To facilitate the HS-DSCH demodulation and decoding, the HS-DSCH is configured according to CQI=1. This is the coding configuration corresponding to 1 HS-PDSCH, QPSK modulation, and the smallest transport block size (so it is the configuration with the lowest effective coding rate).

The minimum requirements for this test are based on the probability of event  $E_m$ , which is declared when the UE is signalled on HS-SCCH1, but DTX is observed in the corresponding HS-DPCCH ACK/NACK field.

In addition to the 4 HS-SCCHs and the HS-DSCH, the UE must transmit all the W-CDMA downlink channels required to establish and maintain a connection. The channel configuration for the DPCH corresponds to the RMC 12.2 kbps. Refer to 34.121 section E.5.1 for more information on the configuration for the downlink physical channels. 6 OCNS channels are also transmitted to account for the energy transmitted to other users in a real BTS (see 34.121 section E.5.2).

The test must be performed under different multi-path fading and AWGN propagation conditions. Two fading scenarios must be considered: ITU Pedestrian A Speed 3km/h (PA3) and ITU vehicular Speed 30km/h (VA30). These scenarios correspond to profiles with 4 to 6 paths and Doppler spectrum. Refer to 34.121 section D.2.2 table D.2.2.1A for more details on these fading profiles.

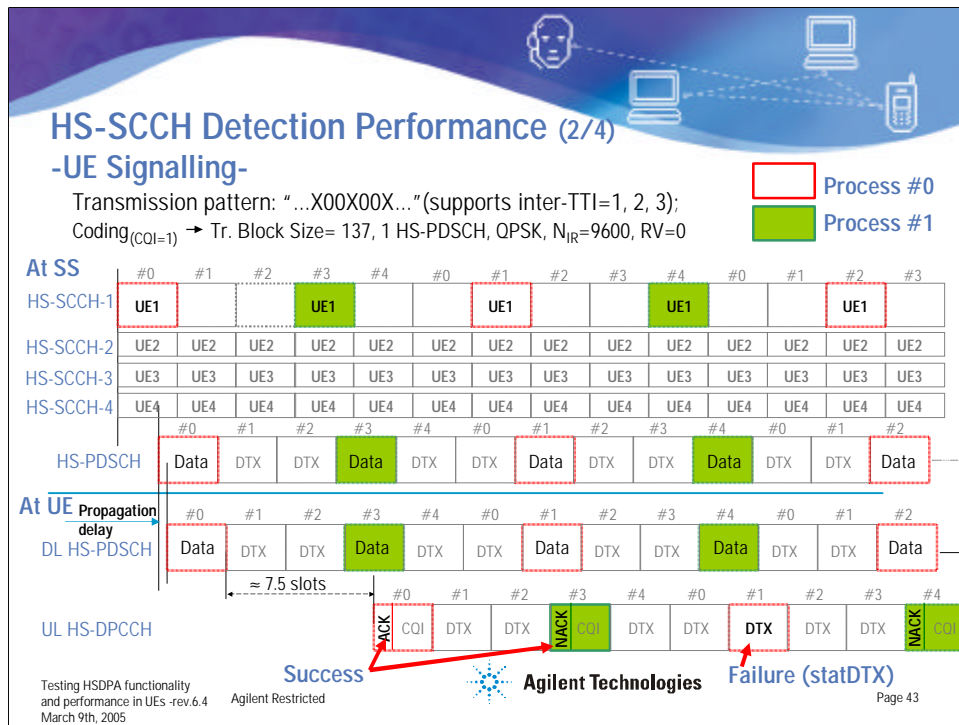

The slide shows as example of the procedure for testing HS-SCCH detection performance. The HS-SCCH1 TTI transmission pattern for this test is defined as "...X00X00X..." to accommodate UEs with minimum inter-TTI interval=3 (and lower). Two parallel processes must be used to support this pattern.

According to the UE procedure for receiving the HS-DSCH (see 26.214 6A.1.1), if the UE did not detect consistent control information intended for it on any of the HS-SCCHs in the HS-SCCH set in the immediately preceding subframe, the UE must monitor all the HS-SCCHs in the HS-SCCH set. If the UE did detect consistent control information intended for this UE in the immediately preceding subframe, it is sufficient to only monitor the same HS-SCCH used in the immediately preceding subframe. For the HS-SCCH detection performance test, the HS-SCCH transmission pattern is discontinuous, so the UE must monitor all the HS-SCCHs every subframe.

The HS-SCCH1 control information is covered with the UE identity. The UE identity for the UE under test is 10101010101010, according to the specifications (see 34.121 table 9.4.2). The other three HS-SCCHs are assigned different UE identities (also in 34.121 table 9.4.2). The UE must be able to detect the signalling from HS-SCCH1.

Once the UE identifies that it is being addressed by HS-SCCH1, it must verify that the first slot of the HS-SCCH carries consistent control information for its UE capability. In other words, it must verify that the decoded 'channelization-code-set information' is lower than or equal to the 'maximum number of HS-DSCH codes received' in its UE capability and that the decoded modulation scheme is valid in terms of its UE capability. The HS-DSCH configuration used for this test is based on COI=1 (transport block size=137, 1 HS-PDSCH, and QPSK modulation) regardless of the UE capability. All UE capabilities support this configuration. So, the UE should be able to recognize that HS-SCCH1 is sending consistent control information.

Once the UE detects that HS-SCCH1 carries consistent control information for it, the UE must start receiving the HS-PDSCHs indicated by this control information.

The UE should also be able to derive the transport block size and the HARQ process information in HS-SCCH1. If it cannot find this information, it discards the HS-SCCH and the associated HS-PDSCH.

If the UE does not recognize the signalling from HS-SCCH1 or it does not detect consistent control information on this channel, neither ACK, nor NACK, is transmitted in the corresponding HS-DPCCH subframe. So, the ACK/NACK field is statDTX. This is recorded as a failure for the HS-SCCH detection performance test.

An ACK or a NACK received from the UE is recorded as a success, since the UE was able to correctly detect the signalling and control information from HS-SCCH1.



## HS-SCCH Detection Performance (3/4)

### - $P(E_m)$ versus BLER-

$$P(E_m) = \frac{(statDTX)}{(NACK + statDTX + ACK)}$$

$$BLER = \frac{(NACK + statDTX)}{(NACK + statDTX + ACK)}$$

Testing HSDPA functionality  
and performance in UEs -rev.6.4  
March 9th, 2005



**Agilent Technologies**

Page 44

The probability of event  $E_m$ ,  $P(E_m)$ , is defined as the ratio between the number of failures and the total number of blocks measured. So,  $P(E_m)$  is equal to  $statDTX/(NACK+statDTX+ACK)$ .

As a reminder, BLER for the Demodulation of HS-DSCH test, is also defined as the ratio between the number of failures and the total number of blocks measured. However, a NACK is considered a failure in the Demodulation of HS-DSCH test. So, BLER is equal to  $(NACK+statDTX)/(NACK+statDTX+ACK)$ .

StatDTX should occur much more infrequently than ACKs or NACKs. The minimum requirements for  $P(E_m)$  are on the order of 1% (from 0.01 to 0.05, depending on the fading profile and test parameters), which is at least one order of magnitude smaller than the BLER minimum requirements for other tests (from 0.1 to 0.97, depending on the actual test, UE category, fading profile, and test parameters).

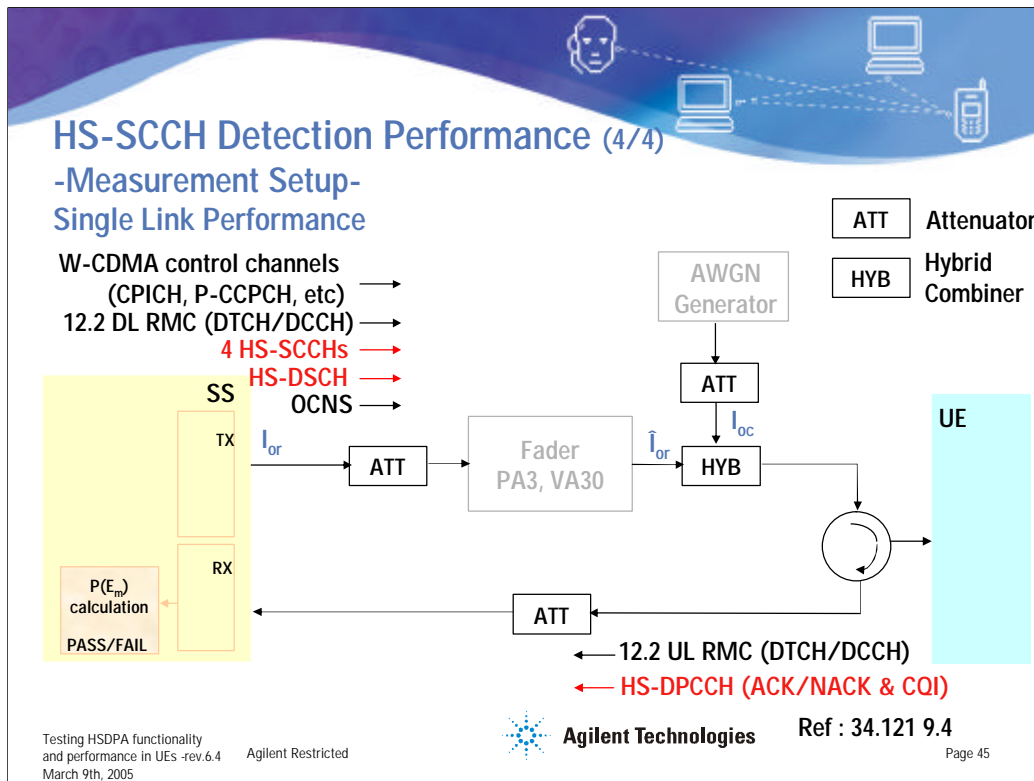

The generic connection diagram for the HS-SCCH detection performance conformance test is shown above. Fading profiles and AWGN might be provided by the system simulator itself, or if not available, by external faders and AWGN sources.

An HSDPA call must be first set up, and the test conditions and test parameters must be set as described in 34.121 section 9.4. The actual minimum requirements for  $P(E_m)$  depend on the actual fading profile and test parameters used. The test is repeated for three different sets of test parameters.

Even though the Release 5 conformance test specifications only describe the single link scenario for the Reporting of CQI tests, the Release 6 specifications will include open loop diversity and closed loop diversity scenarios (see 25.101 version 6.4.0 section 9.4). This presentation is based on Release 5 and only includes the connection setup for the single link performance tests. The connection setup for the diversity cases will probably be similar to the connection setup for the Demodulation of HS-DSCH, open loop diversity and closed loop diversity performance tests, shown earlier in the presentation.



**Which of the following statements about the HS-SCCH detection performance test are correct?**

- If the UE cannot identify the signaling from HS-SCCH1, it sends a NACK
- If the UE cannot identify the signaling from HS-SCCH1, the ACK/NACK field is DTX
- If the UE does not detect control information on HS-SCCH1 that is consistent with its capability, it sends a NACK
- If the UE does not detect control information on HS-SCCH1 that is consistent with its capability, the ACK/NACK field is DTX

Testing HSDPA functionality and performance in UEs -rev.6.4  
March 9th, 2005

Agilent Restricted

 **Agilent Technologies**

Page 46

Information about Q&A:

Which of the following statements about the HS-SCCH detection performance test are correct?

If the UE cannot identify the signaling from HS-SCCH1, it sends a NACK

**False.** A NACK does not indicate problems with the HS-SCCH detection, it only indicates errors in the decoding of the HS-DSCH.

If the UE cannot identify the signaling from HS-SCCH1, the ACK/NACK field is DTX

**True.** For active HS-SCCH1 subframes, this is equivalent to a statDTX, and it is considered a failure.

If the UE does not detect control information on HS-SCCH1 that is consistent with its capability, it sends a NACK

**False.** A NACK does not indicate problems with the HS-SCCH detection, it only indicates errors in the decoding of the HS-DSCH.

If the UE does not detect control information on HS-SCCH1 that is consistent with its capability, the ACK/NACK field is DTX

**True.** This is considered a failure during this test, since any UE (of any UE capability) should be able to handle the control information on HS-SCCH1.



**Which of the following statements about the metric for the HS-SCCH detection performance test are correct?**

- The probability of event  $E_m$  ( $P(E_m)$ ) is used as the metric for this test
- Both the probability of event  $E_m$  ( $P(E_m)$ ) and BLER are used as metrics for this test
- NACKs are considered failures
- DTX reports in the ACK/NACK field are considered failures

Testing HSDPA functionality and performance in UES -rev.6.4 March 9th, 2005      Agilent Restricted       **Agilent Technologies**      Page 47

Information about Q&A:

Which of the following statements about the metric for the HS-SCCH detection performance test are correct?

The probability of event  $E_m$  ( $P(E_m)$ ) is used as the metric for this test

**True.**  $P(E_m) = \text{statDTX} / (\text{ACK} + \text{NACK} + \text{statDTX})$

Both the probability of event  $E_m$  ( $P(E_m)$ ) and BLER are used as metrics for this test

**False.** BLER is not used for this test.

NACKs are considered failures

**False.** NACKs are never considered failures for this test.

DTX reports in the ACK/NACK field are considered failures

**True.** StatDTX reports are considered failures.

## Agenda

### UE Performance Requirements Test Setups

#### Performance Requirements Tests

- Demodulation of HS-DSCH (34.121 9.2)
- Reporting of CQI (34.121 9.3)
  - AWGN Propagation Conditions (34.121 9.3.1)
  - Fading Propagation Conditions (34.121 9.3.2)
- HS-SCCH Detection Performance (34.121. 9.4)

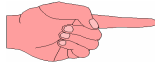

#### Other Non-Conformance Tests

#### Agilent Solutions

#### Summary

Testing HSDPA functionality  
and performance in UES -rev.6.4  
March 9th, 2005

Agilent Restricted



Page 48

The tests discussed until now are part of the conformance tests specifications. Next, some important non-conformance tests for early design verification will be discussed.



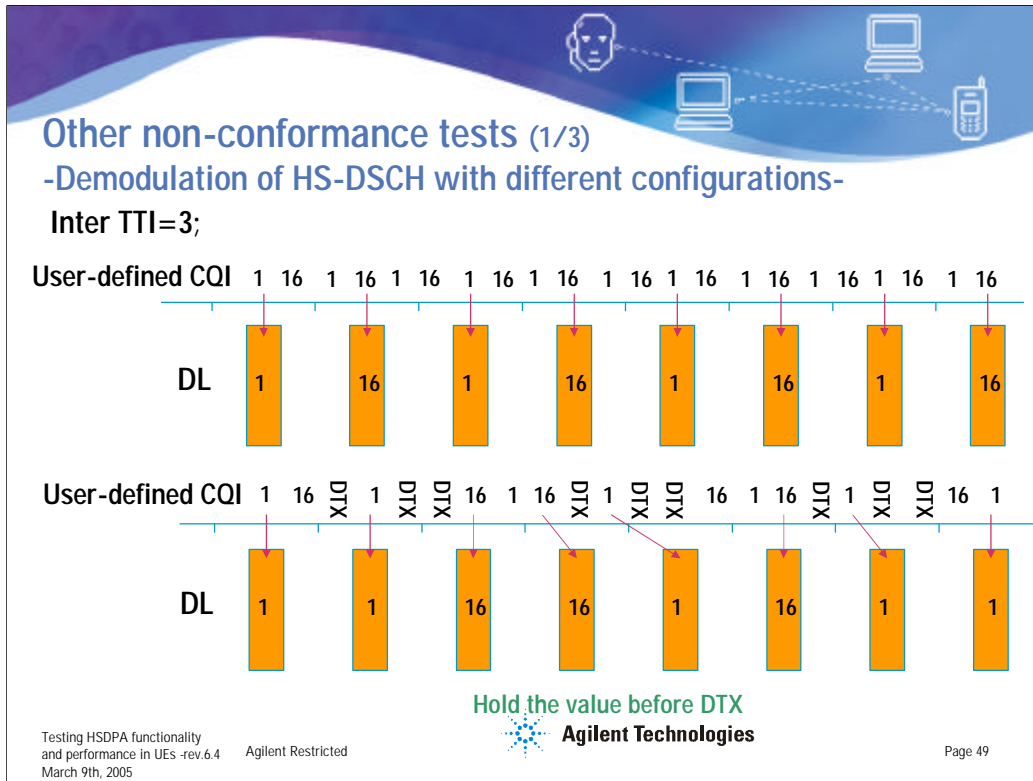

Even though the Demodulation of HS-DSCH conformance test requires a certain fixed channel (fixed modulation and coding), in early design verification different fixed configurations or a more dynamic channel configuration with the coding parameters changing according to the CQI report might be needed to test the UE decoding capabilities thoroughly.

In real life, the Node-B determines the HS-DSCH configuration for a block depending on a number of factors, including the last CQI values reported by all the UEs that it is serving. For this test, the SS or signal generator must configure the HS-DSCH for a block according to a user-defined pattern. If the CQI field corresponding to a certain subframe is DTX, the HS-DSCH configuration for that subframe must correspond to the previous non-DTX CQI value in the pattern. The reported CQI is ignored for the HS-DSCH DTX subframes.

The slide shows two examples for an HS-DSCH with inter-TTI interval = 3. In the top case, configurations corresponding to CQI value 1 and CQI value 16 are alternated. This pattern could test the ability of the UE to demodulate alternating QPSK and 16 QAM formats. The reported CQI is ignored for the HS-DSCH DTX subframes.

In the second case, the CQI pattern contains DTX fields. When the CQI field corresponding to a certain subframe is DTX, the HS-DSCH configuration for that subframe corresponds to the previous non-DTX CQI value in the pattern, as shown.

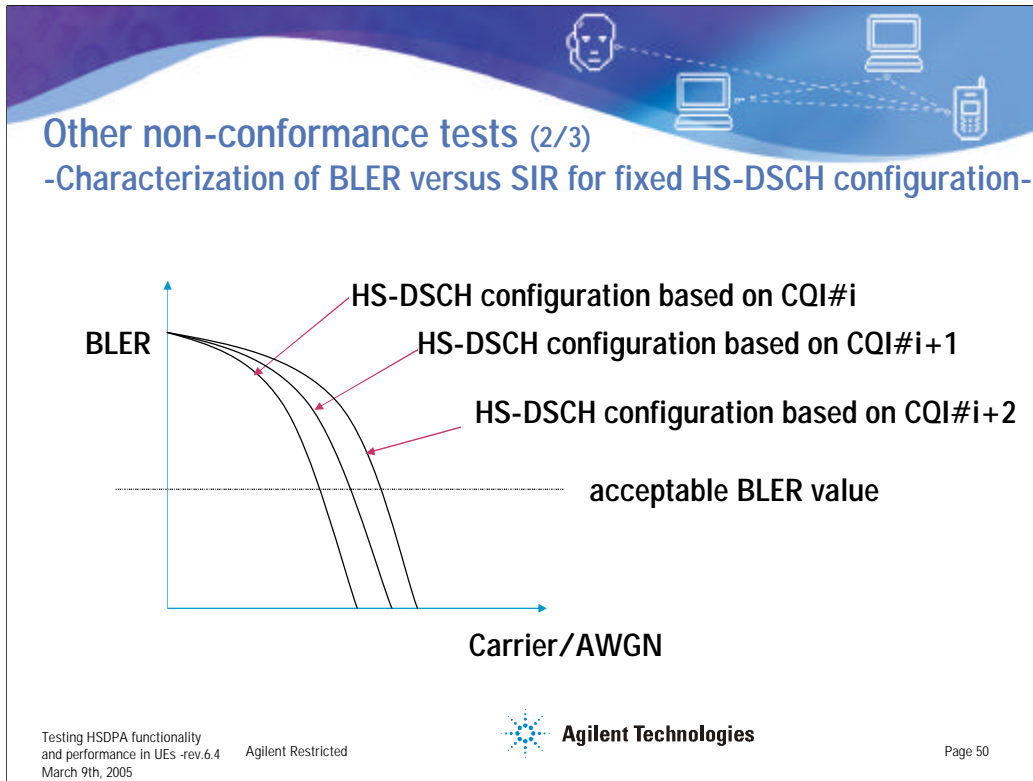

During the design of the CQI derivation algorithm, characterization of the BLER versus the Signal-to-Interference Ratio (SIR) for each HS-DSCH configuration based on each CQI value might be required to determine the maximum CQI whose corresponding HS-DSCH configuration results in an acceptable BLER value for a certain SIR.

This characterization can be performed by configuring the HS-DSCH according to a certain CQI value and testing BLER with different levels of AWGN. This test procedure can be repeated for every CQI value.

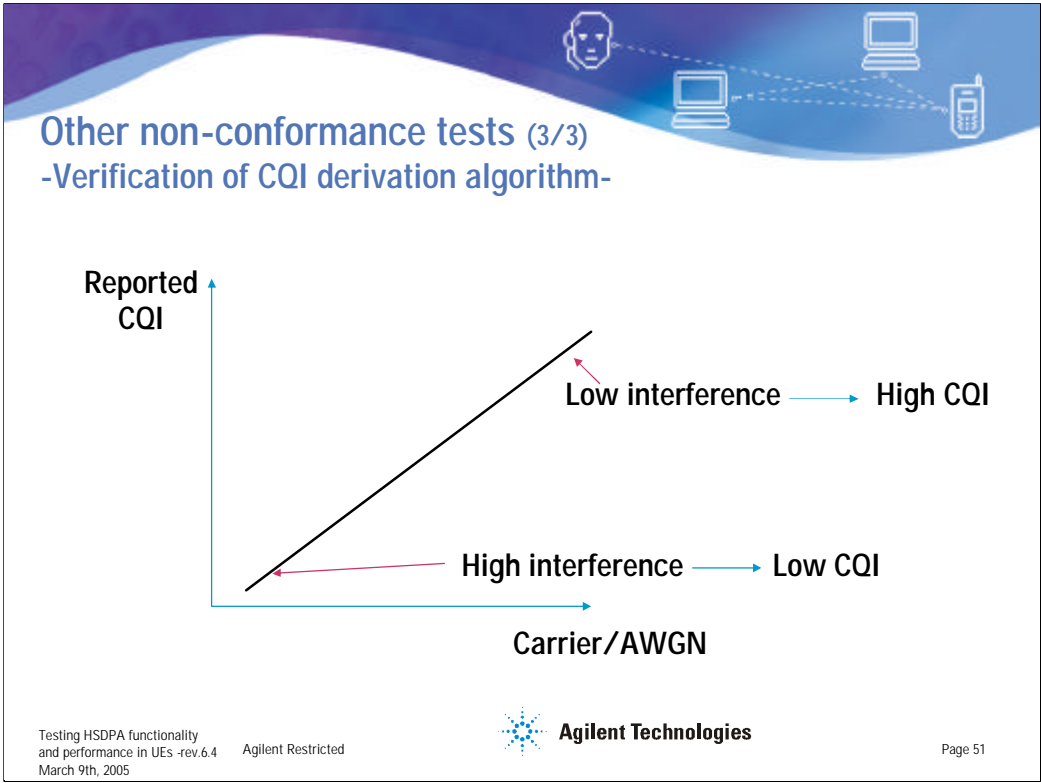

Once the derivation algorithm has been created, the designer can also verify the functionality of the CQI derivation algorithm by configuring the HS-DSCH according to a certain CQI value and checking that the reported CQI varies as expected for different AWGN levels.

## Agenda

### UE Performance Test Setups

### Performance Requirements Tests

- Demodulation of HS-DSCH (34.121 9.2)
- Reporting of CQI (34.121 9.3)
  - AWGN Propagation Conditions (34.121 9.3.1)
  - Fading Propagation Conditions (34.121 9.3.2)
- HS-SCCH Detection Performance (34.121. 9.4)

### Other Non-Conformance Tests

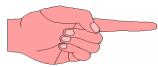

### Agilent Solutions

### Summary

Testing HSDPA functionality  
and performance in UES -rev.6.4  
March 9th, 2005

Agilent Restricted



Page 52

The rest of the presentation describes the solutions from Agilent for early design verification, including baseband design verification, for the tests discussed during this paper.

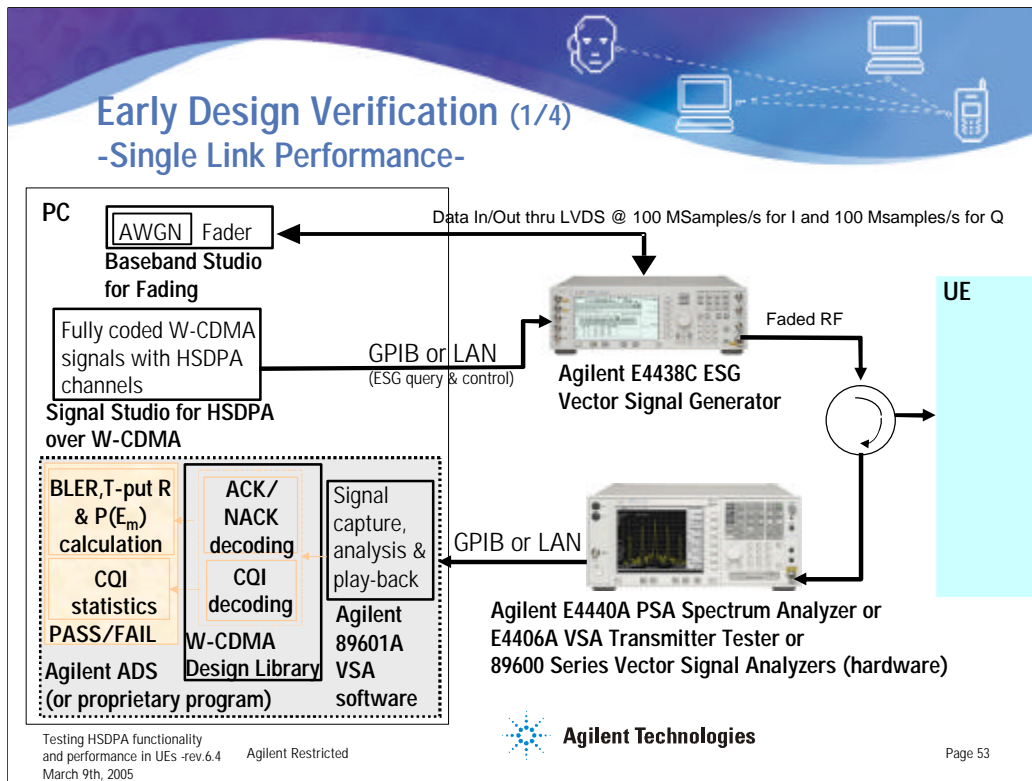

As an alternative solution to perform the tests discussed in this presentation during early design verification, the combination of a signal generator, signal analyzer and EDA software can be used. The signal generator must provide W-CDMA signals with fully coded HSDPA channels. The solution proposed in the slide consists of a signal generator (Agilent E4438C Vector Signal Generator) combined with a software option that allows generation of W-CDMA signals with fully coded HSDPA channels (Agilent Signal Studio for HSDPA over W-CDMA), a signal analyzer (Agilent E4440A PSA spectrum analyzer, E4406A VSA transmitter tester, or 89600 vector signal analysis hardware, combined with the 89601A vector signal analysis software) to receive and capture the uplink signal, and analyze the HS-DPCCH channel and demodulated (coded) bits reported from the UE, and ADS software with HSDPA behavioral components (included in the ADS W-CDMA Design Library) that perform the decoding of the ACK/NACK and CQI fields. The calculations for t-put R, BLER, and  $P(E_m)$ , and analysis of the CQI statistics can also be implemented within ADS. If ADS is not available, a proprietary program could also be used to perform the HS-DPCCH decoding and processing.

Fading and AWGN are provided in the signal generator via an innovative combination of hardware and software called Baseband Studio for Fading. The fading software feeds the fading algorithm into an external FPGA residing in a PC that provides delay for each path and employs DSP to perform complex multiplication on the original baseband signal with the chosen fading scenario. The fader is linked to the signal generator via an LVDS high speed digital interface.

Baseband Studio for Fading also provides AWGN generation. Adding noise to the faded signal changes the total power level as well as the carrier to noise ratio (C/N). In order to calibrate the noise level to the incoming signal power, it is necessary to determine the carrier power after fading. This can be a time-consuming process, since many measurements must be taken at several output power levels to get a statistically correct pdf. Baseband Studio for Fading eliminates these time-consuming measurements by seamlessly integrating the AWGN and fading capabilities with the E4438C ESG.

The main drawbacks of the alternative solution provided by the signal generator and signal analyzer (and EDA or proprietary software) relative to a true SS is that there is no ACK/NACK feedback loop for the Demodulation of HS-DSCH test. The ACK/NACK feedback from the UE must be simulated at the signal generator. The signal generator uses user-defined ACK/NACK patterns to determine whether a block must be retransmitted. The ACK/NACK patterns simulate the UE behavior. Even though the test does not provide a truthful t-put R result, this alternative solution can be used to verify the HS-DSCH decoding, including IR, during early design verification. This alternative setup can also be used to perform the Reporting of CQI and HS-SCCH detection performance tests, since the test procedures for these tests can be followed without the need of a direct feedback loop.

The other drawback of the signal generator/signal analyzer (and EDA/proprietary software) solution is that a call cannot be set up as required by the conformance specifications. This should not have a direct impact on the measurement results.

The main advantage of this alternative solution is that it is more flexible than a SS, so it allows for more thorough testing of the HSDPA functionality during early design verification. For example, it can be used to perform the non-conformance tests

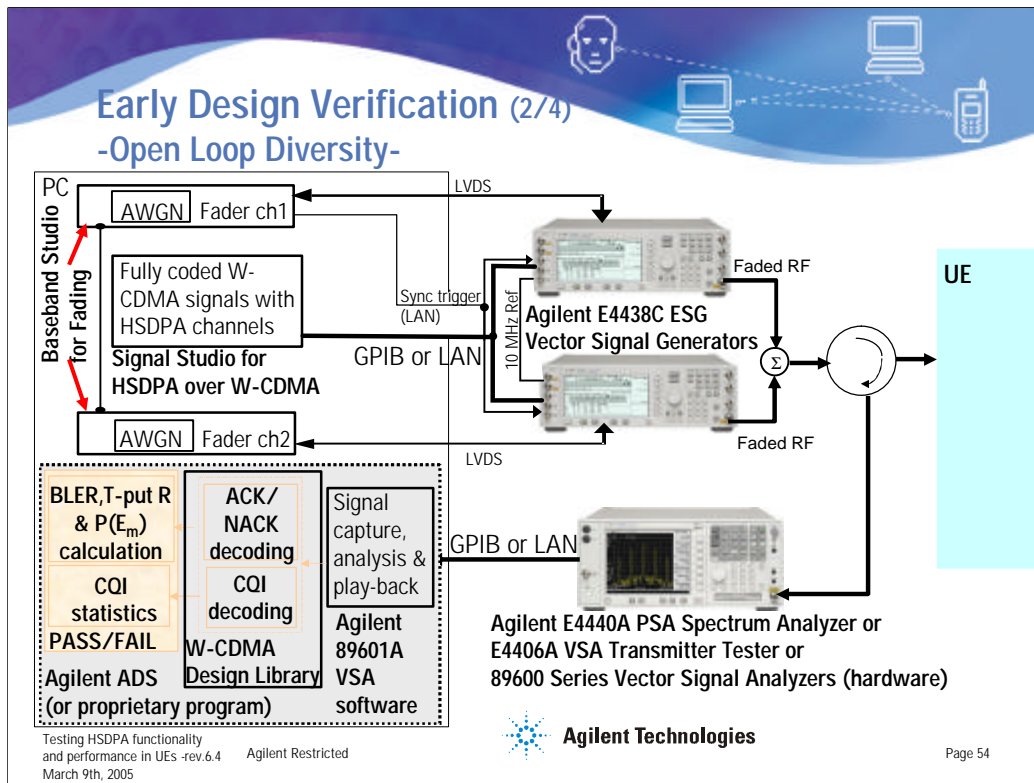

Alternative solutions for open loop diversity based on signal generators require two signal generators, one for each antenna. The two signal generators must be synchronized, so that the correlation between the antennas can be precisely controlled, which simulates the physical distance between the two antennas.

Two Baseband Studio PCI Cards and two ESG signal generators can be synchronized together for dual channel applications, such as required for transmit diversity, as shown in the slide.

Closed loop diversity cannot be implemented easily using signal generators because of the lack of a feedback loop.



## Early Design Verification (3/4)

### -Ordering information-

#### Signal Generator Configuration

**E4438C ESG vector signal generator with options:**

E4438C - 503 - 250 kHz to 3 GHz frequency range

E4438C - 602 - Internal baseband generator, 64 Msa memory with digital bus capability

E4438C - 1E5 - High-stability time-base – Now free

E4438C - 418 - Signal Studio for HSDPA over W-CDMA

#### Baseband Studio Configuration

**N5101A Baseband Studio PCI Card**

**N5115A Baseband Studio for Fading**

N5115A – 160 -- One fading channel with up to 17 MHz RF bandwidth

N5115A – 168 -- Add AWGN to one fading channel

N5115A – 170 -- ESG signal generator connectivity for one fading channel

See [www.agilent.com/find/esg](http://www.agilent.com/find/esg) and [www.agilent.com/find/basebandstudio](http://www.agilent.com/find/basebandstudio) for more information.

**Note: The dual channel configuration for open loop diversity requires two ESG signal generators and two Baseband Studio PCI Cards and associated options.**

Testing HSDPA functionality  
and performance in UES -rev.6.4  
March 9th, 2005

Agilent Restricted

 **Agilent Technologies**

Page 55

The next two slides provide the ordering information for the Agilent solutions recommended for early design verification. This slide provides the signal generator configuration for early design verification (single link performance and open loop diversity).



## Early Design Verification (4/4)

### -Ordering information-

#### Signal Analyzer Configuration

E444xA PSA series spectrum analyzer with options:

E444xA - B7J - Digital Demodulation hardware

E444xA - BAF - W-CDMA measurement personality

E444xA - 210 - HSDPA measurement personality

or E4406A vector signal analyzer with options:

E4406A - BAF - W-CDMA measurement personality

E4406A - 210 - HSDPA measurement personality

89601A vector signal analysis software with options:

89601A - 200 - Basic analysis software

89601A - 300 - Hardware connectivity

89601A - B7N - 3GPP modulation analysis

89601A - 105 - ADS streaming interface

#### EDA Configuration

E8900A - ADS 2004A

E8850A - Communications Systems Designer

E8875A - 3GPP Design Library

E5720A - Connection Manager

Testing HSDPA functionality  
and performance in UES -rev.6.4  
March 9th, 2005

Agilent Restricted



Page 56

This slide provides the signal analyzer and EDA configuration for early design verification (single link performance and open loop diversity).



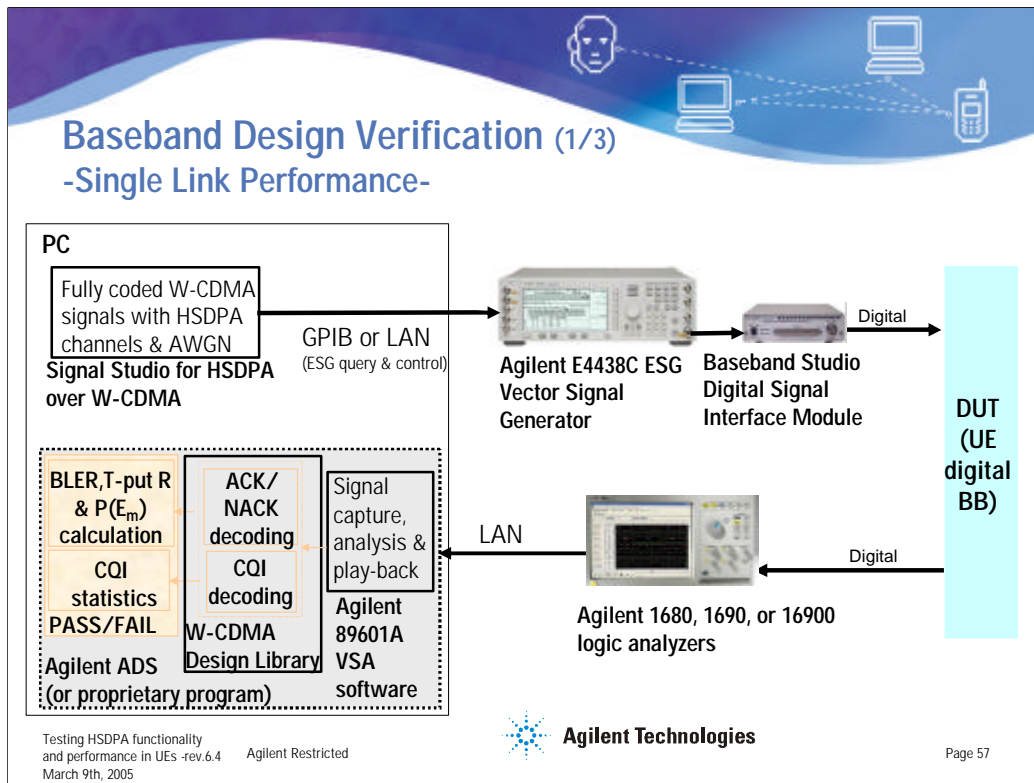

If the DUT has digital inputs or outputs, a similar measurement setup can be used to perform the HSDPA tests discussed. Agilent Studio for HSDPA over W-CDMA is used in combination with the Agilent E4438C ESG vector signal generator to generate W-CDMA downlink signals with fully coded HSDPA channels. The Baseband Studio Digital Signal Interface Module (DSIM) is used to provide fast digital inputs and outputs for the E4438C ESG vector signal generator.

Please note Baseband Studio for Fading cannot be used in conjunction with Baseband Studio DSIM. So, fading cannot be performed with this setup. AWGN can be generated directly by Signal Studio for HSDPA over W-CDMA.

A logic analyzer is used to capture the digital output signal from the DUT and transfer it to ADS. The digital signal can be transferred directly to ADS or captured first with the 89601A vector signal analysis software, if spectrum, modulation, or code domain analysis of the uplink signal is required, for troubleshooting purposes. Agilent 1680, 1690, and 16900 logic analyzers offer connectivity with ADS and with the 89601A vector signal analysis software and can be used for these measurement applications. The logic analyzer can also be used to identify problems in the digital domain.

Finally, ADS or a proprietary program can be used to decode the ACK/NACK and COI reports from the UE and calculate the different measurement metrics.



## Baseband Design Verification (2/3)

### -Ordering information-

#### Signal Generator Configuration

E4438C ESG vector signal generator with options:

E4438C - 503 - 250 kHz to 3 GHz frequency range

E4438C - 602 - Internal baseband generator, 64 Msa memory with digital bus capability

E4438C - 003 - Digital output connectivity

E4438C - 004 - Digital input connectivity

E4438C - 1E5 - High-stability time-base – Now free

E4438C - 418 - Signal Studio for HSDPA over W-CDMA

N5102A Baseband Studio Digital Signal Interface Module

See [www.agilent.com/find/esg](http://www.agilent.com/find/esg) and [www.agilent.com/find/basebandstudio](http://www.agilent.com/find/basebandstudio) for more information.

This slide provides the signal generator and DSIM configuration for the baseband design verification setup.

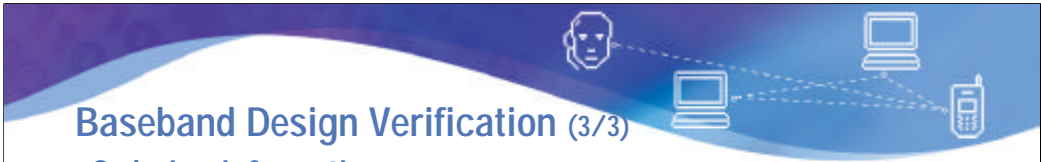

## Baseband Design Verification (3/3)

### -Ordering information-

**Logic analyzer configuration (ex: single-ended system with digital clock rates <= 250 Mb/s)**

<p><b>16903A 3-slot mainframe</b></p> <p><b>16911A 68-channel state analyzer</b></p> <p>Option choices:</p> <p>001 (1M sample depth),</p> <p>004 (4M sample depth),</p> <p>016 (16M sample depth),</p> <p>032 (32M sample depth)</p> <p>014 (Gbit ethernet LAN interface)</p>	<p><b>Choose one of the following types of probes:</b></p> <ul style="list-style-type: none"> <li>- E5404A Soft Touch Pro connectorless probe (34 channels/probe)</li> <li>- E5383A flying lead probes (17 channels / probe)</li> <li>- E5346A mictor connector probes (34 channels / probe)</li> <li>- E5385A Samtec connector probes (34 channels / probe)</li> </ul>
---	---

<p><b>89601A vector signal analysis software with options:</b></p> <p>89601A - 200 - Basic analysis software</p> <p>89601A - 300 - Hardware connectivity</p> <p>89601A - B7N - 3GPP modulation analysis</p> <p>89601A - 105 - ADS streaming interface</p>	<p><b>EDA Configuration</b></p> <p>E8900A - ADS 2004A</p> <p>E8850A - Communications Systems Designer</p> <p>E8875A - 3GPP Design Library</p> <p>E5720A - Connection Manager</p>
---	--

Testing HSDPA functionality and performance in UES -rev.6.4  
March 9th, 2005



**Agilent Technologies**

Page 59

This slide provides the logic analyzer, 89601A software, and EDA configuration for the baseband design verification setup.

## Signal Studio for HSDPA over W-CDMA (1/7)

### -Overview-

Channel	State	Power (dB)	Power (dBm)	Ec/No	Code	SF	Data	Modulation
CPCH	<input checked="" type="checkbox"/>	-6.63	-21.34 dBm	-6.63	0	256	--	QPSK
SSCH	<input checked="" type="checkbox"/>	-11.63	-26.34 dBm	--	--	--	--	--
P-CPCH	<input checked="" type="checkbox"/>	-8.63	--	--	1	256	BCH	QPSK
PICH	<input type="checkbox"/>	-8.30	--	--	3	256	PN9	QPSK
DPCH	<input checked="" type="checkbox"/>	-13.53	-28.24 dBm	-13.53	10	512	PN9	QPSK
HS-PDSCH1	<input checked="" type="checkbox"/>	-13.53	-28.24 dBm	-13.53	4,5,6,7	16	PN9	16QAM
DSCH2	<input type="checkbox"/>	-10.20	--	--	9	16	PN9	16QAM
DSCH3	<input checked="" type="checkbox"/>	-19.86	-34.57 dBm	-19.86	9	16	PN9	16QAM
DSCH4	<input type="checkbox"/>	-10.20	--	--	10	16	PN9	16QAM
SCCH1	<input checked="" type="checkbox"/>	-13.53	-28.24 dBm	-13.53	1	128	STD	QPSK
SCCH2	<input type="checkbox"/>	-10.20	--	--	1	128	STD	QPSK
HS-SCCH3	<input checked="" type="checkbox"/>	-13.53	-28.24 dBm	-13.53	1	128	STD	QPSK
HS-SCCH4	<input type="checkbox"/>	-10.20	--	--	1	128	STD	QPSK
OCNS1	<input type="checkbox"/>	-6.63	--	--	1	128	PN9	QPSK
OCNS2	<input type="checkbox"/>	-8.30	--	--	1	128	PN9	QPSK
OCNS3	<input type="checkbox"/>	-8.30	--	--	1	128	PN9	QPSK
OCNS4	<input type="checkbox"/>	-10.20	--	--	1	128	PN9	QPSK
OCNS5	<input type="checkbox"/>	-7.30	--	--	1	128	PN9	QPSK
OCNS6	<input type="checkbox"/>	-8.30	--	--	1	128	PN9	QPSK

Testing HSDPA functionality and performance in UEs -rev.6.4  
March 9th, 2005

Agilent Technologies

Page 60

The following slides describe the Agilent solution capabilities for testing of the UE HSDPA functionality and performance during early design verification and baseband design verification.

First, the capabilities of Signal Studio for HSDPA over W-CDMA will be discussed. The slide shows an overview of the features of Signal Studio for HSDPA over W-CDMA software for UE testing. The most important feature for testing UEs is the ability to create downlink transport and physical layer coded HSDPA signals for performing analysis of BLER and of the other metrics discussed during this presentation. The transport layer coding configuration can be modified or turned off for troubleshooting applications.

The software enables the user to generate up to 15 multicodes, and select either QPSK or 16QAM for the downlink HSDPA transmissions. This is useful for testing the demodulation and decoding algorithms in the baseband section.

The next feature is the ability to configure the W-CDMA common control channels. Although these are not part of the HSDPA capability, they are needed to establish a radio link between the UE and the ESG.

Other features are the ability to generate up to 16 OCNS channels and AWGN. 6 OCNS channels and AWGN interference are required by the specifications to perform the HSDPA performance requirements tests under realistic conditions.

One final feature is generating up to 4 downlink HS-DSCHs and the corresponding HS-SCCHs. This is useful for testing whether the UE can correctly identify the appropriate channel to demodulate and decode.

Next, the more critical features of Signal Studio for HSDPA over W-CDMA for each of the tests discussed in the presentation will be described.

## Signal Studio for HSDPA over W-CDMA (2/7)

### -Demodulation of HS-DSCH-

User control of ACK/NACK pattern

User control of HARQ parameters

Agilent Technologies

Testing HSDPA functionality and performance in UEs -rev.6.4 March 9th, 2005
Agilent Restricted
Page 61

The Demodulation of HS-DSCH test requires the SS to react to the ACK/NACK report of the UE by transmitting new data or retransmitting the data block accordingly. As mentioned earlier, the signal generator cannot react to the true ACK/NACK report from the UE, because of the lack of a feedback loop. Therefore, the Demodulation of HS-DSCH test cannot be performed as required if a signal generator-based solution is used.

However, the DSCH decoding, and in particular the HARQ functionality, can still be evaluated if the signal generator solution allows user control of the HARQ parameters (maximum number of transmissions, RV sequence, etc) and user control of the ACK/NACK pattern that simulates the UE ACK/NACK-response behavior. The slide shows the graphical user interface of Signal Studio for HSDPA over W-CDMA for the HS-DSCH transport layer. The coding parameters (transport block size, number of HARQ processes, HARQ parameters) can be configured by the user. The ACK/NACK pattern can be manually setup or imported from a file.

Another important feature for this test is the ability to select a pre-configured FRC and RMC 12.2 kbps. Signal Studio allows quick setup of pre-configured FRCs and RMC 12.2 kbps.

## Signal Studio for HSDPA over W-CDMA (3/7)

### -Demod of HS-DSCH w/different configurations-

**Inter TTI interval=3; CQI=15,16 repeat**

**DL** 15 16 15 16 15 16 15 16

**UL CQI** 15 16 15 16 15 16 15 16 15 16 15 16

Testing HSDPA functionality and performance in UEs -rev.6.4 March 9th, 2005

Agilent Restricted

Page 62

Signal Studio for HSDPA over W-CDMA allows the HS-DSCH to be configured according to different CQI values (so different modulation and coding) for every subframe. This feature can be used during early design verification to test the UE's capability to decode the HS-DSCH with different fixed configurations or with configurations that vary according to the user-defined CQI pattern in order to simulate a dynamic AMC environment.

The slide shows a user-defined CQI pattern, in which CQI values 15 and 16 are alternated. There are no DTX CQI fields. The downlink HS-DSCH is configured with inter-TTI interval=3 (the HS-DSCH configuration interface is not shown in the slide). Therefore, a block is sent on the HS-DSCH every three subframes. The CQI value is ignored for the HS-DSCH DTX subframes, as shown at the bottom of the slide.

Two code domain analysis displays for the HS-DSCH with this configuration are also shown. The first one corresponds to subframe #0 (coding based on CQI=15), and it shows a code domain power display with 5 HS-PDSCHs and the QPSK constellation for one of them, as expected. The second display corresponds to subframe #3 (coding based on CQI=16), and it shows the code domain power display with 5 HS-PDSCHs and the 16 QAM constellation for one of them, as expected. The symbol power versus time is also displayed and shows the power for one of the HS-PDSCHs (code number 4) over time, which is bursty, as expected with a signal configured with inter-TTI interval=3.

## Signal Studio for HSDPA over W-CDMA (4/7) -Reporting of CQI-

Inter-TTI interval=3

User control of CQI pattern

Agilent Signal Studio for HSDPA over W-CDMA -- CQIpattern1\_16.xml

Project\Channels\HSDPA1

HSDPA1 (High Speed Downlink Packet Access)

State ON

Block Size 4664

Block Size Info 36

Number of Hybrid ARQ Process 2

Inter TTI 3

UEID 0

Redundancy Version Parameter 0

Feedback Control AMC

HARQ\_Maximum Number of HARQ Transmission 1

HARQ\_Redundancy Version Parameter 0,0,0,0,0,0,0

HARQ\_ACK/NAK Pattern ACK ALL

AMC\_UE Category 5

AMC\_CQI Pattern USER

HS-DSCH

HS-DSCH Incremental Redundancy Buffer Size 8600

HS-DSCH Data PN9

HS-PDSCH

HS-PDSCH State ON

HS-PDSCH Power -10.20 dB

HS-PDSCH Code Offset 4

HS-PDSCH Number of Codes 4

Inter TTI

Sets the inter transmission time interval [PK<1..18|USER]

0 E4439C 2.000 000 000 000 GHz -10.00 dBm

Testing HSDPA functionality and performance in UES -rev.6.4 March 9th, 2005 Agilent Restricted

Agilent Technologies

Page 63

The Reporting of CQI tests require user control of the HS-DSCH coding parameters. The user must be able to configure the HS-DSCH according to CQI=16, median-CQI, median-CQI+2, and median-CQI-1, for the different parts of the tests.

As mentioned earlier, Signal Studio for HSDPA over W-CDMA allows the user to configure the HS-DSCH for each subframe according to a user-defined CQI pattern. So, for example, as shown in the slide, the HS-DSCH coding can be fixed according to CQI value 16 and the transmitting pattern can be set as "...X00X00...", as required by the specifications.

## Signal Studio for HSDPA over W-CDMA (5/7)

### -Tests for CQI derivation design and verification-

C/N setting

Channel	State	Power (dB)	Power (dBm)	Ec/No	Code	SF	Data	Modulation
CPICH	<input checked="" type="checkbox"/>	-3.30 dB	-19.64 dBm	-4.97 dB	0	256	--	QPSK
PSCH	<input checked="" type="checkbox"/>	-8.30 dB	-24.64 dBm	--	--	--	--	--
SSCH	<input checked="" type="checkbox"/>	-8.30 dB	-24.64 dBm	--	--	--	--	--
P-CCPCH	<input checked="" type="checkbox"/>	-5.30 dB	-21.64 dBm	-6.97 dB	1	256	BCH	QPSK
PICH	<input type="checkbox"/>	-8.30 dB	--	--	3	256	PN9	QPSK
DPCH	<input checked="" type="checkbox"/>	-10.20 dB	-26.54 dBm	-11.87 dB	10	512	PN9	QPSK
HS-PDSCH1	<input checked="" type="checkbox"/>	-10.20 dB	-26.54 dBm	-11.87 dB	4,5,6,7,8	16	PN9	16QAM
HS-PDSCH2	<input type="checkbox"/>	-10.20 dB	--	--	8	16	PN9	16QAM
HS-PDSCH3	<input type="checkbox"/>	-10.20 dB	--	--	9	16	PN9	16QAM
HS-PDSCH4	<input type="checkbox"/>	-10.20 dB	--	--	10	16	PN9	16QAM
HS-SCCH1	<input checked="" type="checkbox"/>	-10.20 dB	-26.54 dBm	-11.87 dB	4	128	STD	QPSK
HS-SCCH2	<input type="checkbox"/>	-10.20 dB	--	--	5	128	STD	QPSK
HS-SCCH3	<input type="checkbox"/>	-10.20 dB	--	--	6	128	STD	QPSK
HS-SCCH4	<input type="checkbox"/>	-10.20 dB	--	--	7	128	STD	QPSK

Testing HSDPA functionality and performance in UEs -rev.6.4  
March 9th, 2005

Agilent Technologies

Page 64

Another important feature during the design and verification of the CQI derivation algorithm is the ability to add different levels of AWGN to the stimulus signal. As mentioned earlier in the presentation, this is required to characterize the BLER versus the Signal-to-Interference Ratio (SIR) for each HS-DSCH configuration based on each CQI value, during early design of the CQI derivation algorithm.

Generation of different levels of AWGN is also required to verify that the reported CQI value varies as expected with the AWGN level.

Signal Studio for HSDPA over W-CDMA allows the user to add AWGN to the signal, even without the presence of Baseband Studio for Fading.



## Signal Studio for HSDPA over W-CDMA (6/7) -HS-SCCH Detection Performance-

Channel	State	Power (dB)	Power (dBm)	Eir/No	Code	SF	Data	Modulation
SSCH	☑	-6.38 dB	-24.25 dBm	--	--	--	--	--
PCPCH	☑	-6.38 dB	-24.25 dBm	4.95 dB	1	256	SCCH	QPSK
PRCH	☐	-6.38 dB	--	--	3	256	PRB	QPSK
DPCH	☐	-18.20 dB	-25.16 dBm	-11.45 dB	10	120	DC1	QPSK
HS-DSCH-1	☐	-18.20 dB	-25.16 dBm	-11.45 dB	4	16	HS-DSCH	QPSK
HS-DSCH-2	☐	-18.20 dB	--	--	8	16	PRB	16QAM
HS-DSCH-3	☐	-18.20 dB	--	--	9	16	PRB	16QAM
HS-DSCH-4	☑	-18.20 dB	--	--	10	16	PRB	16QAM
HS-SCCH1	☑	-18.20 dB	-25.16 dBm	-11.45 dB	11	120	STC	QPSK
HS-SCCH2	☑	-18.20 dB	-25.16 dBm	-11.45 dB	5	120	PRB	QPSK
HS-SCCH3	☑	-18.20 dB	-25.16 dBm	-11.45 dB	6	120	PRB	QPSK
HS-SCCH4	☑	-18.20 dB	-25.16 dBm	-11.45 dB	7	120	PRB	QPSK

Testing HSDPA functionality and performance in UES -rev.6.4 March 9th, 2005

Agilent Technologies

Page 65

The most important feature for the HS-SCCH detection performance test is the ability to transmit HS-SCCHs without the presence of associated HS-DSCHs. Signal Studio for HSDPA over W-CDMA provides this capability, as shown in the slide. According to this measurement setup, 4 HS-SCCHs are transmitted, while only 1 HS-DSCH is transmitted, as required by the specifications for this test.

## Signal Studio for HSDPA over W-CDMA (7/7) -Open Loop Diversity-

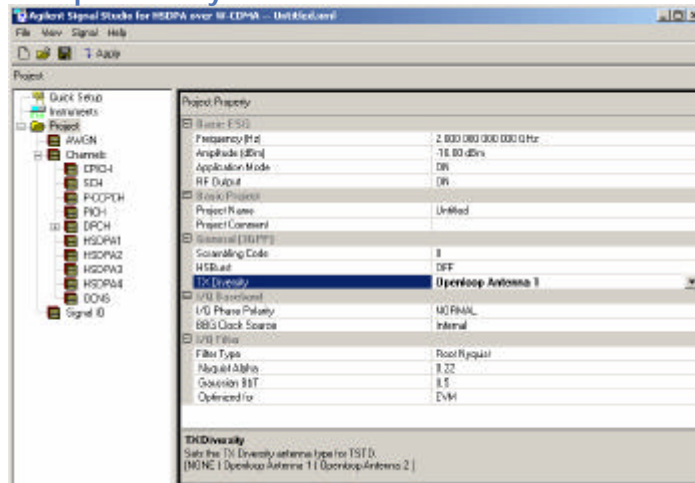

Testing HSDPA functionality  
and performance in UES -rev.6.4  
March 9th, 2005

Agilent Restricted



Page 66

For open loop diversity, the signal generators must have the ability to be configured to act as the openloop antenna 1 or 2. Signal Studio for HSDPA over W-CDMA provides this capability, as shown in the slide.

## Signal Analysis (1/3) -HS-DPCCH ACK/NACK analysis-

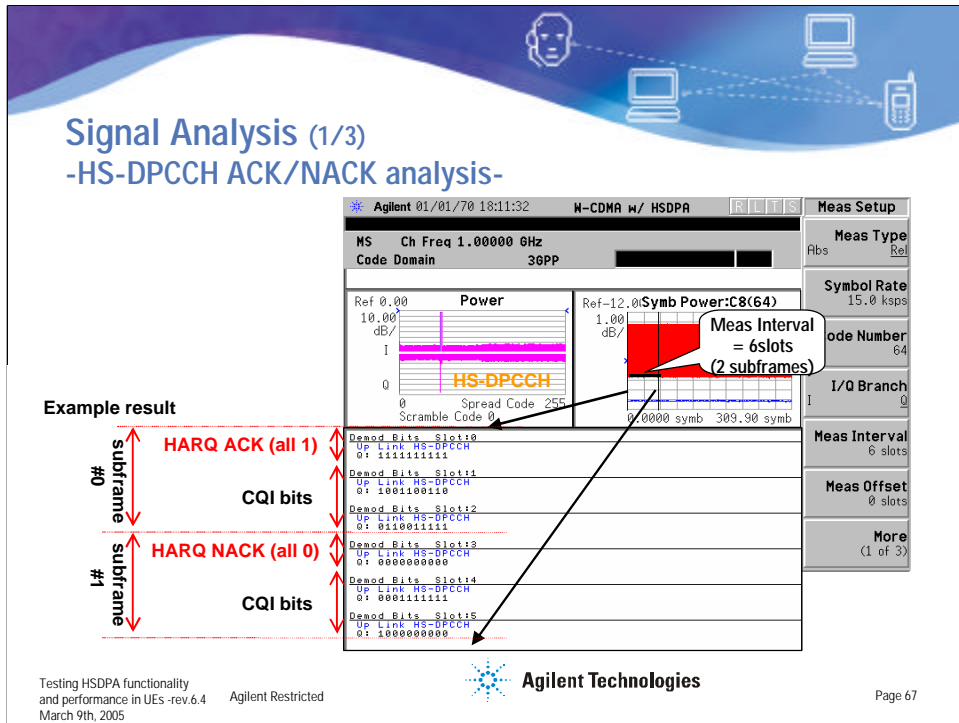

The signal analyzer capabilities required for the different tests are described next. The signal analyzer (or either the logic analyzer or the Baseband Studio DSIM for digital DUTs) must be capable of capturing the uplink signal from the UE. If ADS is used, the baseband signal can be captured into the 89601A vector analysis software, which can be implemented as a sink element within ADS, so that further analysis in ADS can be performed (ACK/NACK and CQI decoding, tput R, BLER, and  $P(E_m)$  calculation, and analysis of the CQI statistics).

In addition to capturing the signal and transferring it to ADS, the signal analyzer can be useful during early design stages to analyze the uplink signal and troubleshoot problems in the HS-DPCCH transmission from the UE. If the signal analyzer has W-CDMA code domain analysis capabilities, the HS-DPCCH can be despread and analyzed just as any other W-CDMA uplink channel. For example, the total power of the HS-DPCCH can be verified in the code domain power display, or the power of the ACK/NACK and the CQI fields versus time can be examined in the symbol power versus time display.

The demodulation bits for multiple subframes (up to 80 subframes) can be examined in the demod bits display, as shown in the slide for 2 subframes. From this display, it is easy to manually decode the HARQ ACK field into an ACK (ten '1's) or a NACK (ten '0's). This can be useful to verify the ACK/NACK coding during early design stages or to troubleshoot problems detected during the Demodulation of HS-DSCH, Reporting of CQI, and HS-SCCH detection performance tests, since the minimum requirement metrics for these tests are mainly based on the ACK/NACK report.

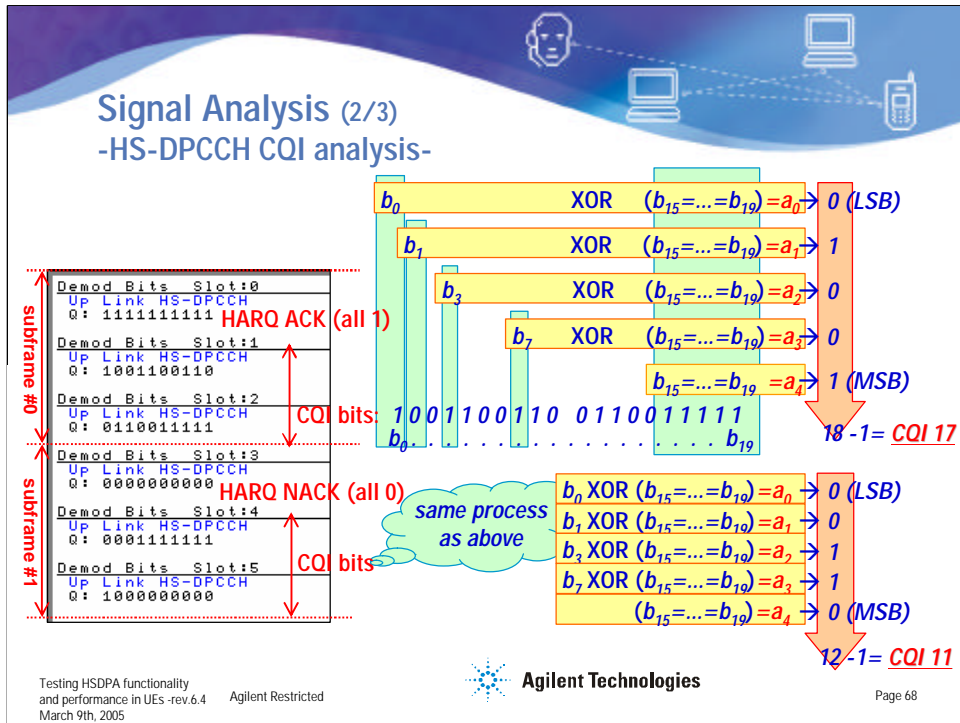

The demodulated bits for the CQI field can also be examined and the CQI field manually decoded, although this involves a lengthier and more cumbersome process, as shown earlier.

This slide shows an example of the manual HS-DPCCH decoding process to extract CQI values from the demod bits result for the measured HS-DPCCH. In the demod bit display here, the 10 bits of slot #0 and slot#3 are HARQ-ACK/NACK bits for subframes #0 and #1.

The following 20 bits of the two consecutive slots (#1 and #2 for subframe#0, and #4 and #5 for subframe #1) contain CQI code word bits  $b_0 \dots b_{19}$ .

As mentioned earlier, during the coding, the CQI values 0...30 are converted to binary 5-digit CQI bit sequences from (00001) to (11111), which are coded into a 20-bit-long binary encoded CQI word  $b_0 \dots b_{19}$ . So, the decoding process must first decode the 5-digit CQI bits from the 20-bit long CQI word, and then convert the 5-digit CQI bits back to the decimal CQI values. Note that (00001) corresponds to 0, not 1, and (11111) corresponds to 30, not 31.

In this example, the CQI decimal values are manually extracted from the measured CQI code word bits  $b_0 \dots b_{19}$  in the demod bits display. For simplicity, error correction during the decoding process from 20 to 5 bits is not taken into account.

The example above assumes UE category 1. The extracted CQI value "17" can be looked up in 25.214 Table 7A and corresponds to a Transport Block Size = 4189, number of HS-PDSCHs = 5, and 16 QAM modulation. A reference power adjustment = 0,  $N_{IR} = 9600$ , and  $RV = 0$  are assumed.

The extracted CQI value "11" can be looked up in 25.214 Table 7A and corresponds to a Transport Block Size = 1483, number of HS-PDSCHs = 3, and QPSK modulation. A reference power adjustment = 0,  $N_{IR} = 9600$ , and  $RV = 0$  are assumed.

## Signal Analysis (3/3) - Excel VBA HS-DPCCH Decoding Tool-

Sub F#	HARQ-ACK	CQI
0	ACK	DTX
1	NACK	8
2	DTX	13
3	ACK	15
4	NACK	25
0	DTX	DTX
1	ACK	8
2	NACK	13
3	DTX	15
4	ACK	25
0	NACK	DTX
1	DTX	8
2	ACK	13
3	NACK	15

Control Panel:

- HS-DPCCH Code#: 54
- PSANSA Address: psa27
- Subframe Delay (256 Chip Units): 15

Testing HSDPA functionality  
and performance in UEs -rev.6.4  
March 9th, 2005

Agilent Restricted

Agilent Technologies

Page 69

You can use an external excel visual basic for applications (VBA) macro to extract the despread HS-DPCCH signal from the PSA/E4406A and automatically decode the ACK/NACK and CQI fields. The number of decoded HS-DPCCH subframes is determined by the analyzer's capture length used for the measurement.

Note: The excel macro shown in this slide is an internal Agilent tool. Please contact your local AE if you are interested in having a copy.

## ADS W-CDMA Design Library (1/2) -HS-DPCCH ACK/NACK and CQI decoding-

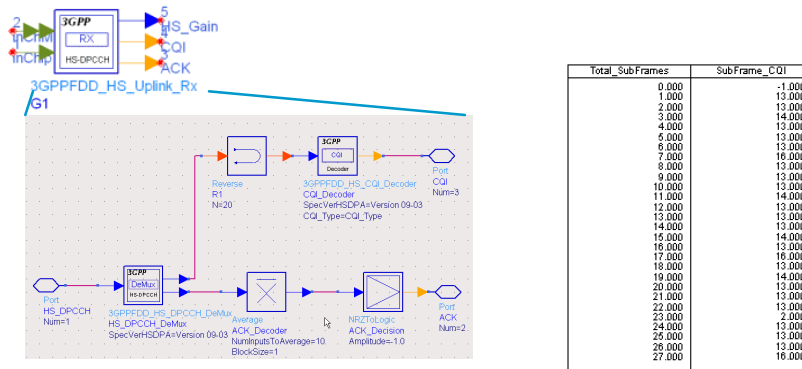

Testing HSDPA functionality  
and performance in UEs -rev.6.4  
March 9th, 2005

Agilent Restricted



Page 70

If ADS is available, connectivity between ADS and the Agilent signal analyzers and logic analyzers can be used to obtain a longer capture of the uplink signal and transfer it to ADS, as mentioned earlier. The behavioral HSDPA decoder in the ADS W-CDMA design library can perform the ACK/NACK and CQI decoding, without the need of a user-programmed method.

The high level schematic for the ADS HSDPA decoder is shown in the slide. The decoded CQI results for an uplink signal example are also shown. Signal Studio for HSDPA over W-CDMA was used instead of a UE to generate the uplink signal example.

# ADS W-CDMA Design Library (2/2)

## -Calculation of metrics-

### HSDPA BLER Results Summary

Total_SubFrames	Total_ACKs	Total_NACKs	Cumulative_BLER	SubFrame_CQI
0.000	0.000	0.000	0.000	-1.000
1.000	1.000	0.000	0.000	13.000
2.000	2.000	0.000	0.000	13.000
3.000	2.000	1.000	33.333	14.000
4.000	3.000	1.000	25.000	13.000
5.000	4.000	1.000	20.000	13.000
6.000	4.000	2.000	33.333	13.000
7.000	5.000	2.000	28.571	16.000
8.000	6.000	2.000	25.000	13.000
9.000	6.000	3.000	33.333	13.000
10.000	7.000	3.000	30.000	15.000
11.000	8.000	3.000	27.273	14.000
12.000	8.000	4.000	33.333	13.000
13.000	9.000	4.000	30.769	13.000
14.000	10.000	4.000	28.571	13.000
15.000	10.000	5.000	33.333	14.000
16.000	11.000	5.000	31.250	13.000
17.000	12.000	5.000	29.412	16.000
18.000	12.000	6.000	33.333	13.000
19.000	13.000	6.000	31.579	14.000
20.000	14.000	6.000	30.000	13.000
21.000	14.000	7.000	33.333	13.000

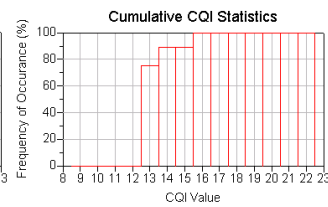
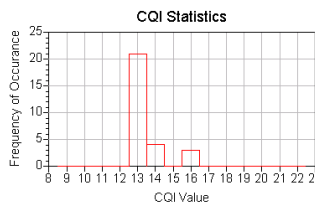

Testing HSDPA functionality and performance in UEs -rev.6.4 March 9th, 2005

Agilent Restricted



Page 71

ADS also allows further processing of the decoded ACK/NACK and CQI values. Equations and graphics can be created to calculate the different metrics. The BLER calculation for an uplink signal example generated with Signal Studio for HSDPA over W-CDMA is shown in the slide. The CQI frequency distribution and cumulative frequency distribution that are needed to calculate the median and variance of the CQI are also shown.



## Summary

**Testing of HSDPA functionality and performance in UEs involves three main areas: HS-DSCH decoding (including the multi-code capability and the HARQ functionality), CQI reporting, and detection of HS-SCCH.**

**These areas are addressed by the HSDPA performance requirements conformance tests in Release 5 of the 3GPP specifications.**

**Variations of these tests can be useful during early design verification**

**Even though a SS is required for conformance testing, alternative solutions based on a signal generator are more flexible and can be useful during early design verification**

**Agilent provides solutions to verify the HSDPA functionality and performance in UEs during early design verification**

Testing HSDPA functionality and performance in UEs -rev.6.4  
March 9th, 2005

Agilent Restricted



**Agilent Technologies**

Page 72

As a summary, testing of HSDPA functionality and performance in UEs involves three main areas of the UE functionality, which coincide with the more challenging aspects of the new HSDPA functions: the HS-DSCH decoding (including the multi-code demodulation capability and the HARQ functions, such as the IR combining, that take place during the decoding process), the CQI reporting (including the CQI derivation algorithm and coding), and the detection of the HS-SCCH.

These same three areas are respectively addressed by the three HSDPA performance requirements tests in section 9 of the conformance test specifications (Release 5 and beyond).

During early design verification, it might not be possible to perform the tests as required by the specifications, if full functionality to establish a call is not available. Variations of these tests or similar tests can be useful to verify the design thoroughly. Alternative solutions based on a signal generator might be a better option in these early stages of the design because they are more flexible. Agilent provides solutions to verify the HSDPA functionality and performance in UEs during early design verification, including baseband design verification.





**Reference Documents**  
([www.3gpp.org](http://www.3gpp.org))

<b>3GPP TS 25.101 V.6.6.0</b> UE Radio Transmission and Reception (FDD)	<b>3GPP TS 25.308 V.5.7.0</b> HSDPA Overall description
<b>3GPP TS 34.121 V.5.6.0</b> Terminal Conformance Specification. Radio Transmission and Reception (FDD)	<b>3GPP TS 25.321 V.5.a.0</b> Medium Access Control (MAC) Protocol Specification
<b>3GPP TS 25.211 V.5.6.0</b> Physical Channels and Mapping of Transport Channels onto Physical Channels (FDD)	<b>3GPP TR 25.858 V.5.0.0</b> High Speed Downlink Packet Access Physical Layer Aspects
<b>3GPP TS 25.212 V.5.9.0</b> Multiplexing and Channel Coding (FDD)	<b>3GPP TR 25.877 V.5.1.0</b> High Speed Downlink Packet Access: Iub/Iur Protocol Aspects
<b>3GPP TS 25.213 V.5.5.0</b> Spreading and Modulation (FDD)	<b>3GPP TR 25.950 V.4.0.0</b> UTRA High Speed Downlink Packet Access
<b>3GPP TS 25.214 V.5.a.0</b> Physical Layer Procedures (FDD)	
<b>3GPP TS 25.306 V.5.9.0</b> UE Radio Access Capabilities	

Testing HSDPA functionality and performance in UEs -rev.6.4 March 9th, 2005      Agilent Restricted

 **Agilent Technologies**

Page 73

A listing of some of the Release 5 and Release 6 specifications that relate to HSDPA and that were used when developing this presentation is shown above.